

## DISCIPLINED TIME AND FREQUENCY OSCILLATOR

by

**ROBERT STONE**

Mr. Stone is the Head of the Time and Frequency Section of the Naval Research Laboratory, Washington, D.C.

The aim of the PTTI Program is to provide to the user a coordinated time system that can be referenced to the Naval Observatory. Long-range transfers will be accomplished via the Defense Satellite Communications System satellite link, and short-range transfers will be accomplished by microwave links, UHF links, or any other suitable system.

In concept, a centralized area (in a ship or a shore station) will contain the reference atomic standards (see Figure 1). Cables throughout the station will connect the reference standard to units called Disciplined Time Frequency Oscillators (DTFO). The DTFO is an important part of the concept; it separates the timekeeping function from the user-operator function and eliminates the necessity for frequent calibration, which aids considerably in maintenance. It is also much less expensive to use the DTFO than to employ atomic standards in each of the user spaces.

The initial development of the DTFO is shown in Figure 2. It consists of a servo control, a crystal and oven, and a divider, clock or baud rate generator. Both frequency and time are controlled across the cable. The crystal is a high bake-out, minimum gravity effect, maximum short-term stability, fifth overtone AT cut. (Higher-frequency crystals are under investigation.) The unit will continue to operate at the rate of the crystal whenever the cable is disconnected or, for any reason, control is lost.

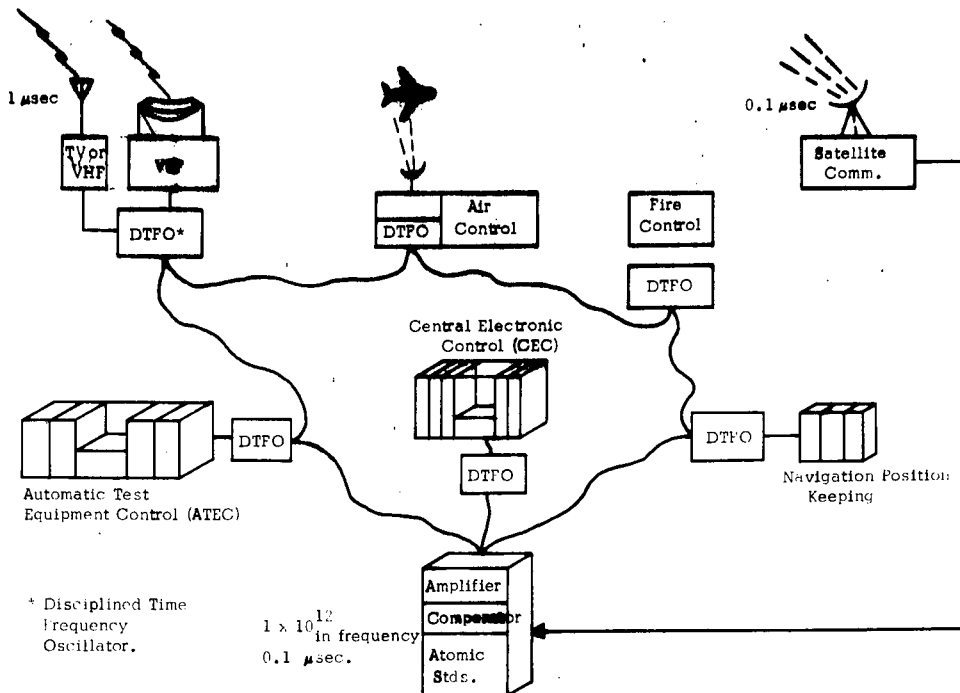

Figure 1. CONCEPT OF LOCAL DISTRIBUTION AND CONTROL FOR DISSEMINATION OF TIME AND FREQUENCY

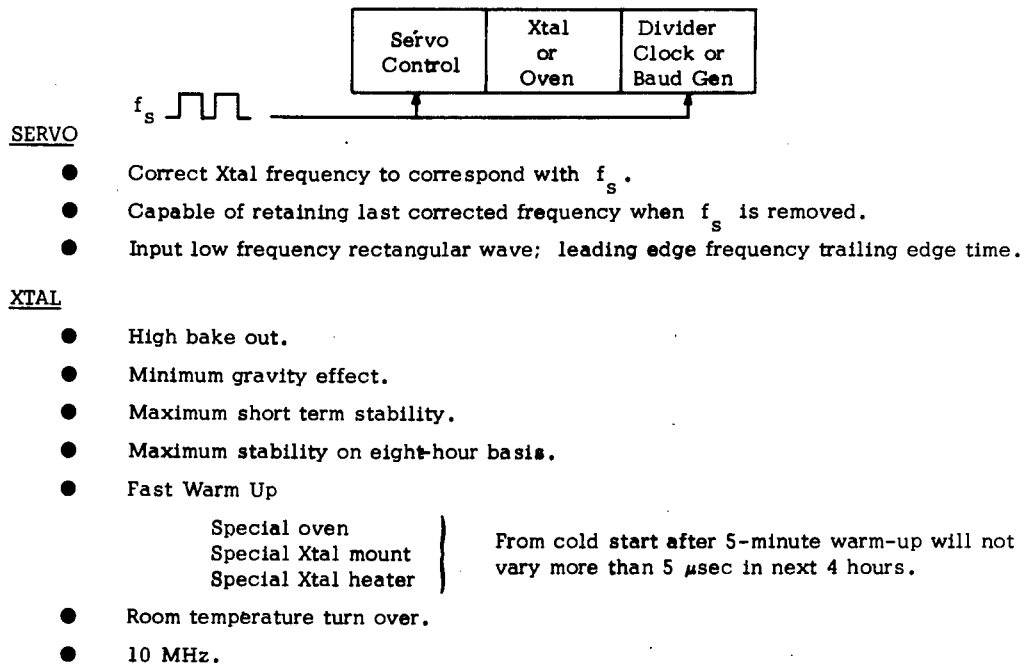

Figure 2. DISCIPLINED TIME/FREQUENCY OSCILLATOR

After the unit is disconnected from the line, no more than 5 microseconds' drift in the next four to five hours is expected.

The unit shown in Figure 3 was produced under contract with the Frequency Electronics Incorporated. It is exactly the same size as the AN/URQ-10 and was designed to replace it. It weighs about 20 pounds.

The battery charger (see Figure 4) has one automatic and several manual positions for charging the battery. There are two time constants. When the system is initially set up, a manual slew adjust helps bring it into "lock." The coarse adjust is about a part in  $10^7$ , the fine adjust is a part in  $10^{11}$ . The meter circuitry has 12 positions; it indicates the 5-megahertz or the 1-megahertz reference input, the battery charging current, battery voltage, power supply lines, oven, output voltages, etc. Normally the operator will monitor the VCO voltage and the sync lights. The sync light flashes at 1 pulse/sec; short flashes indicate the unit is operative, but running on the internal oscillator alone; longer flashes indicate the unit is being synchronized by the external standard. The "unlock" light refers to the frequency only. If something happens to the control line, this light will turn on.

There are several ways of using the device. It can be locked from 5 megahertz or 1 megahertz (in the back of the unit). Separate references can be used for frequency and time, or the 1 pulse/sec can be imposed on the 1-megahertz input at the back of the unit, which locks time and frequency over the same cable. The continuous condition is used for synchronizing if a continuous stream of time pulses is available. If synchronization is required according to some time-event pulse that is sent down a line or derived from another system, the intermittent condition is used. The switch is slipped to the left to arm, then slipped back to the right. The next pulse to come through will synchronize the system and it will ignore all other pulses until the arming is repeated.

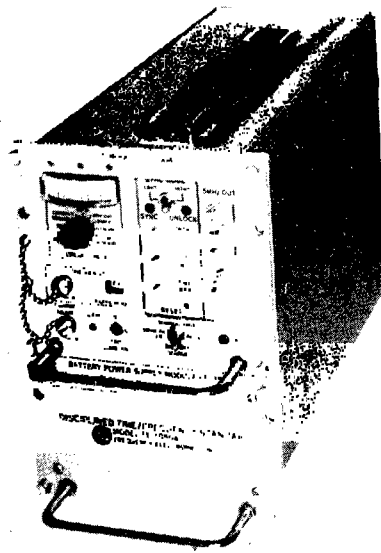

Figure 3. DISCIPLINED TIME/FREQUENCY STANDARD

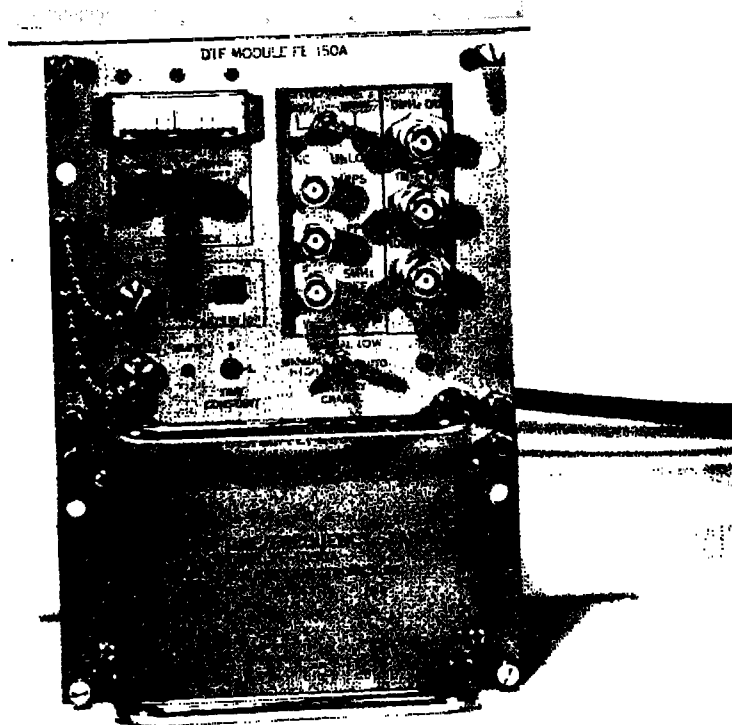

Figure 4. DISCIPLINED TIME/FREQUENCY STANDARD

At the back of the unit (see Figure 5) are the various outputs, sine wave and square wave. It is questionable whether one should ever revert to sine wave once a square wave or a pulse is produced. The 100 kilohertz is a square wave and interfaces well with digital systems. The unit will operate from an external DC supply.

The completely modularized unit is shown disassembled in Figure 6. The front panel, which contains the switches, is separate. The first module contains the crystal and oven assembly, itself modularized. The unit shown below the crystal is the control circuit for the crystal. The memory with its input and output control sections is also shown. Connectors on the front and the back of the module make it quite easy to change the functions of the module without disrupting the system. As the unit is developed and more is learned about how it should really be made, it will be possible to change individual modules without disrupting the entire system.

Figure 7 shows technical specifications of the disciplined time/frequency standard. The outputs of the system are sine wave: 5 megahertz, 1 megahertz; square wave: 100 kilohertz; pulse: 1 pulse/sec, 1 million pulses/sec. The levels are sine waves, 1 volt; square waves, 5 volts; pulses, 5 volts into 50 ohms. These pulses are exactly 20 microseconds wide. Since they are picked from the divider chain, they are controlled on both ends; this was done to be TTL-compatible. The cable jacks are so isolated that if something happens on one of the lines, it does not disrupt the system. A short on one of the cables will not affect the others.

Inputs are high impedance; harmonics, -40 db; spurious, -110 db below the signal level. The first unit, now being subjected to a complete checkout at NRL, is stable and performs very well. Initial test show it to be the quietest unit at NRL.

As previously stated, coarse range adjustment (see Figure 7) is a part in  $10^7$ , and fine adjustment is a part in  $10^{11}$ . Input frequencies are 5 megahertz and 1 megahertz. To provide a special clock frequency or timing

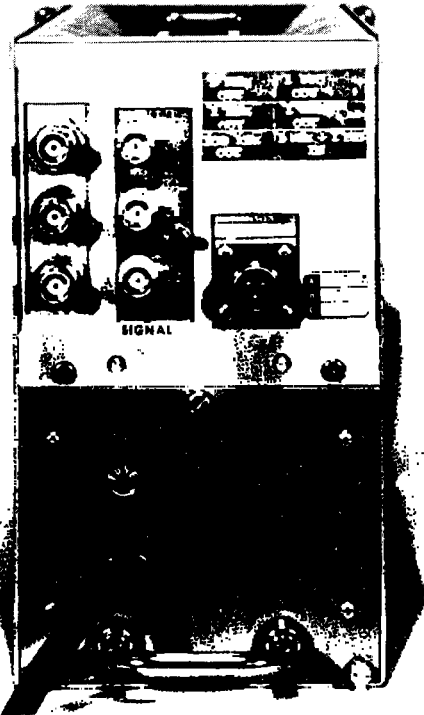

Figure 5. POWER SUPPLY MODULE FE-250A

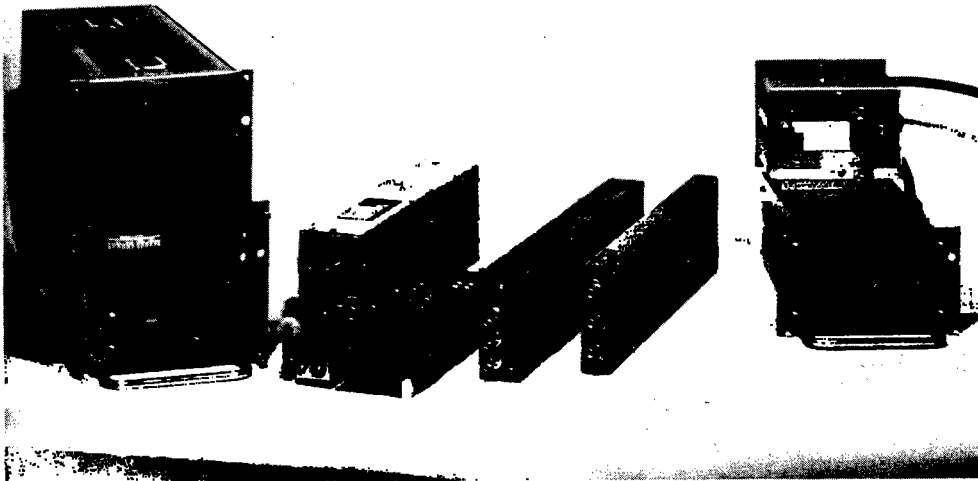

Figure 6. DISASSEMBLED DISCIPLINED TIME/FREQUENCY STANDARD

TECHNICAL SPECIFICATIONS  
DISCIPLINED TIME/FREQUENCY STANDARD

A. SIGNAL

OUTPUT SIGNAL FREQUENCIES:

SINE WAVE: 5 MHz, 1 MHz  
SQUARE WAVE: 100 kHz  
PULSE: 1 PPS, 1 MPPS

OUTPUT SIGNAL LEVELS:

SINE WAVE: 1.0 VRMS ± 20% INTO 50 OHMS  
SQUARE WAVE: 5.0 VPP INTO 1k OHMS  
PULSE:  
1 PPS +5.0V INTO 50 OHMS, 20.0 USEC. WIDE,  
RISE TIME < 20NS.  
1 MPPS 0.1 USEC. WIDE, TTL COMPATIBLE

STABILITY (5 MHz):

100 USEC. AVG. TIME: < 3 PP10<sup>9</sup>  
1 MSEC. AVG. TIME: < 4 PP10<sup>10</sup>  
10 MSEC. AVG. TIME: < 6 PP10<sup>11</sup>  
100 MSEC. AVG. TIME: < 7 PP10<sup>12</sup>  
1 SEC. AVG. TIME: < 3 PP10<sup>12</sup>  
10 SEC. AVG. TIME: < 3 PP10<sup>12</sup>  
100 SEC. AVG. TIME: < 3 PP10<sup>12</sup>  
24 HOURS: < 5 PP10<sup>11</sup>

ISOLATION: ALL OUTPUTS SHORT CIRCUIT PROOF.

SIGNAL INPUT IMPEDANCE: HIGH IMPEDANCE.

SPECTRAL PURITY:

HARMONICS: < -40 dB  
SPURIOUS 5 MHz, 1 MHz: < -110 dB

Noise:

| FREQUENCY<br>FROM CARRIER | SINGLE SIDEBAND<br>NOISE (DB/HZ)<br>REFERENCED TO CARRIER |       |
|---------------------------|---|-------|
|                           | 5 MHz   | 1 MHz |
| 10 Hz                     | -130  | -135  |
| 100 Hz                    | -140  | -140  |
| 1 kHz                     | -160  | -145  |
| 10 kHz                    | -165  | -150  |

OSCILLATOR COARSE ADJ RANGE: 1 PP10<sup>7</sup>

OSCILLATOR FINE ADJ RANGE: DIGITAL INDICATOR 0 TO 999 IN PP10<sup>11</sup>

B. PHASE LOCK FUNCTIONS

INPUT FREQUENCIES:

5 MHz: 1 TO 10 VPP  
1 MHz: 1 TO 4 VPP

RESOLUTION (WITH MEMORY): 2.5 x 10<sup>-12</sup>

PHASE LOCK LOOP FILTER: HERMETICALLY SEALED

TIME CONSTANT: 100 SEC. OR 1 SEC., SWITCH SELECTABLE

CONTROL RANGE: 1 PP10<sup>8</sup>

UNLOCK DETECTOR: RESPONDS TO LOSS OF INPUT SIGNAL LEVEL  
OR PHASE DETECTOR SLIPPAGE

LOCK ACQUISITION: MANUAL CONTROL

C. 1 PPS GENERATOR

SYNCHRONIZATION:

EXTERNAL:  
A) 1 PPS, 1-10 VPP WIDTH > 5 USEC.  
B) 1 PPS + 1 MHz (ALGEBRAICALLY ADDED)  
EQUAL AMPLITUDES OF 1-3 VPP  
PULSE WIDTH > 5 USEC.

SYNC PULSE RISE TIME: 0.1 USEC. MAXIMUM

SYNCHRONIZATION DELAY: 0.1 TO 0.2 USEC.

SYNCHRONIZATION MODE: A) CONTINUOUS (SYNCS TO EVERY INPUT PULSE)  
B) INTERMITTENT (SYNCS TO FIRST PULSE AFTER SWITCH IS THROWN)

1 PPS JITTER (UNSYNCHRONIZED): 0.1 NANOSEC. RMS MAXIMUM

Figure 7. TECHNICAL SPECIFICATIONS DISCIPLINED TIME/FREQUENCY STANDARD

sequence, a small unit must be added or one of the internal modules must be changed. Phase lock of the system is very simple. All critical elements are hermetically sealed, and care has been taken to control parameters so that the unit will be very reliable in the field.

The time constant switch controls two time constants: 100 second and 1 second. The control range is a part in  $10^8$ ; i.e., when the system is being set up, the frequency is adjusted to within a part in  $10^8$ , at which point it will pull in and hold. The synchronization signal is 1 pulse/sec, with amplitude of 1 to 10 volts and width of about 5 microseconds. When 1 pulse/sec is added to a 1-megahertz signal, both time and frequency will be locked. Note the data (Figure 7): 0.1 microsecond on the synchronization pulse rise time; if locking to a signal, the total delay through the unit is 0.1 to 0.2 microsecond. The unit at NRL has always been within 0.1 microsecond.

In Figure 8 the dotted lines represent the different modules in the oscillator. The modules are completely separated, thus well isolated. Because of problems with the memory, the unit will probably be constructed in two versions: one with a volatile memory that will hold only as long as power is supplied, and one with a nonvolatile silicon nitride memory that, if power is lost, will still remember where the oscillator was and that will come back to frequency more rapidly. Two versions may be required because the nonvolatile memory may be prohibitive in cost for those cases in which it is not really needed.

Figure 9 shows the expected stability by time rate measurement (Allan variance). Some points were checked and found to be valid; for instance, the 1-second point was 3 parts in  $10^{12}$ . Some measurements made at the factory have not yet been repeated in the lab. The measurement method is a double chain multiplication system, in which the frequency of a very clean oscillator and the frequency of the oscillator under test are multiplied, then mixed. The difference between them is achieved by an



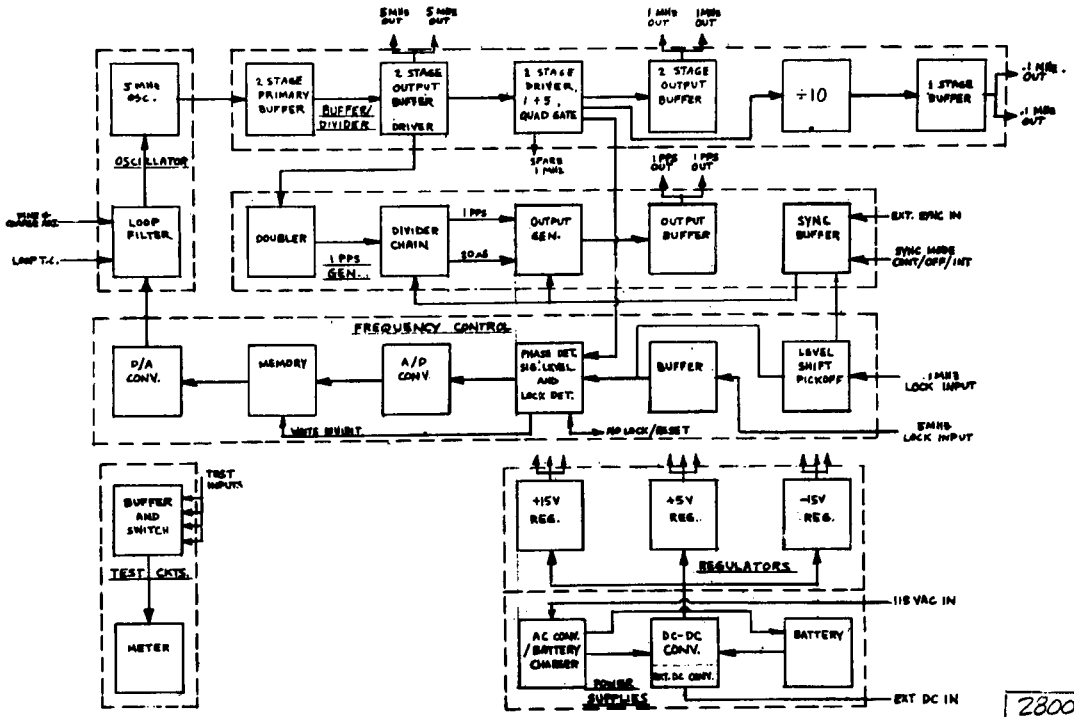

Figure 8. DISCIPLINED TIME/FREQUENCY STANDARD -- PRELIMINARY BLOCK DIAGRAM

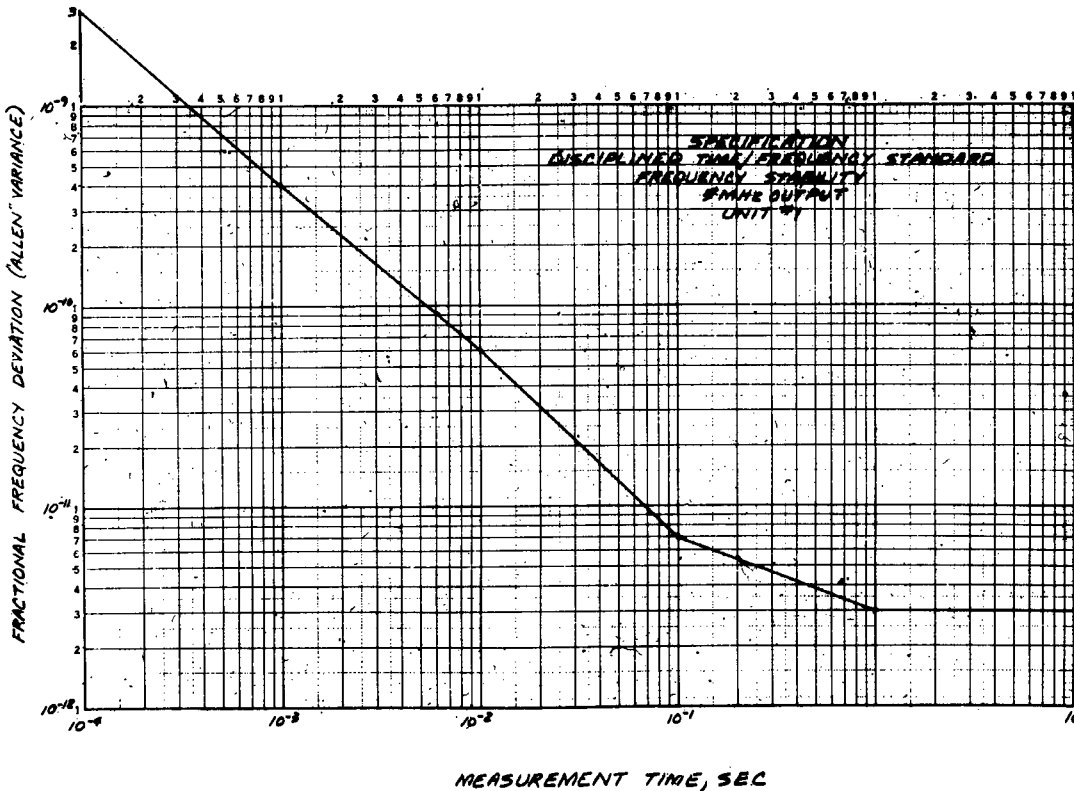

Figure 9. SPECIFICATION DISCIPLINED TIME/FREQUENCY STANDARD FREQUENCY STABILITY, 5 MEGAHERTZ OUTPUT -- UNIT #1

offset of the standard of about 5 kilohertz. This frequency difference is measured with a wave analyzer or a computing counter.

Figure 10 shows the spectral purity of the disciplined time frequency standard. The data were taken on a tracking analyzer. Figure 11, the house standard at Frequency Electronics Incorporated, has a 60-cycle sideband at 107 db and a 120-cycle sideband at 97 db. The disciplined oscillator was added to the system and the sidebands were remeasured. Ten cycles away is 129 db. These sidebands, as far as can be measured, have disappeared well into the noise. It is the cleanest oscillator demonstrated to date.

Figure 12 compares the DTFO locked to a cesium standard with a maser. The cesium beam tube is about five years old and is very noisy. On short time constant, the disciplined oscillator did not clean the signal very well; on long term, however, it did a very good cleaning job. These measurements, called phase recordings, were made on an error multiplier that multiplied the error by 1,000.

The question asked by all is: "If we're going to use this everywhere, what will the cost be?" At present, the one-time tooling cost is about \$35,000. In lots of 100, the expected cost will be in the \$2,000 category; in lots of 1,000, it will be from \$1,380 to \$1,495. However, the cost will range somewhat with different versions of the unit.

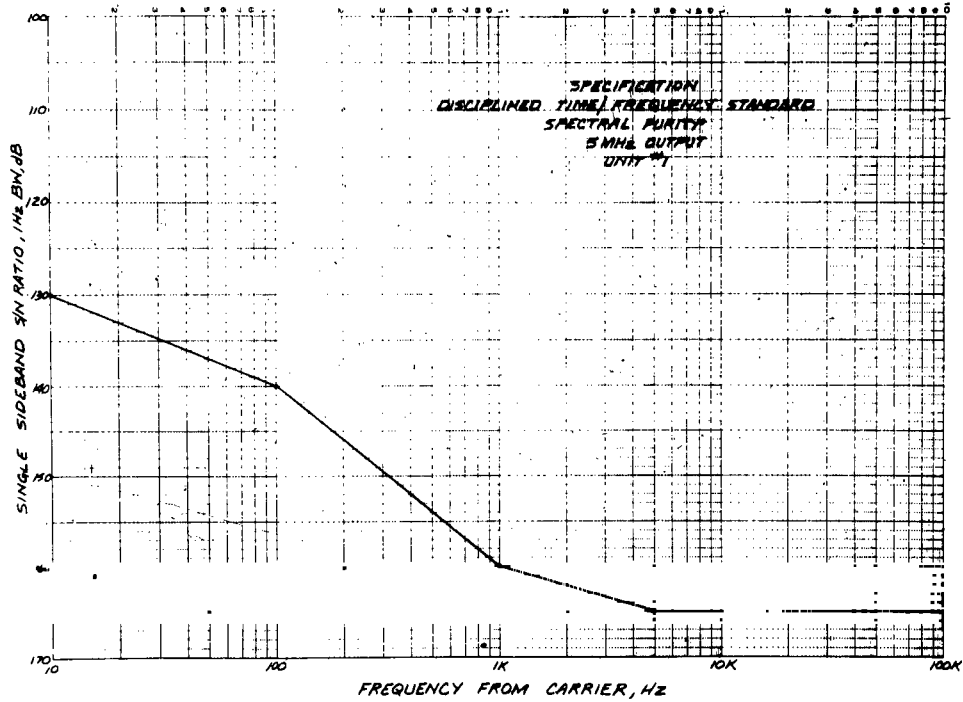

Figure 10. SPECIFICATION DISCIPLINED TIME/FREQUENCY STANDARD SPECTRAL PURITY - 5 MEGAHERTZ OUTPUT - UNIT #1

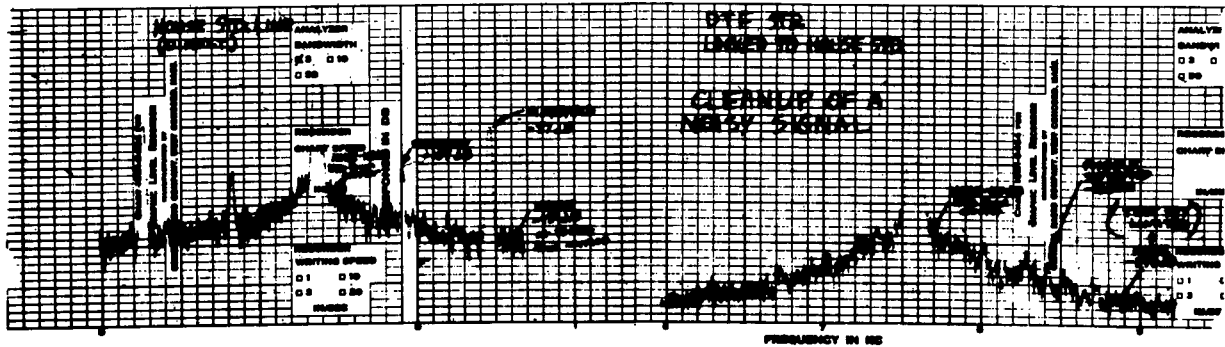

Figure 11. DTF STANDARD LOCKED TO HOUSE STANDARD

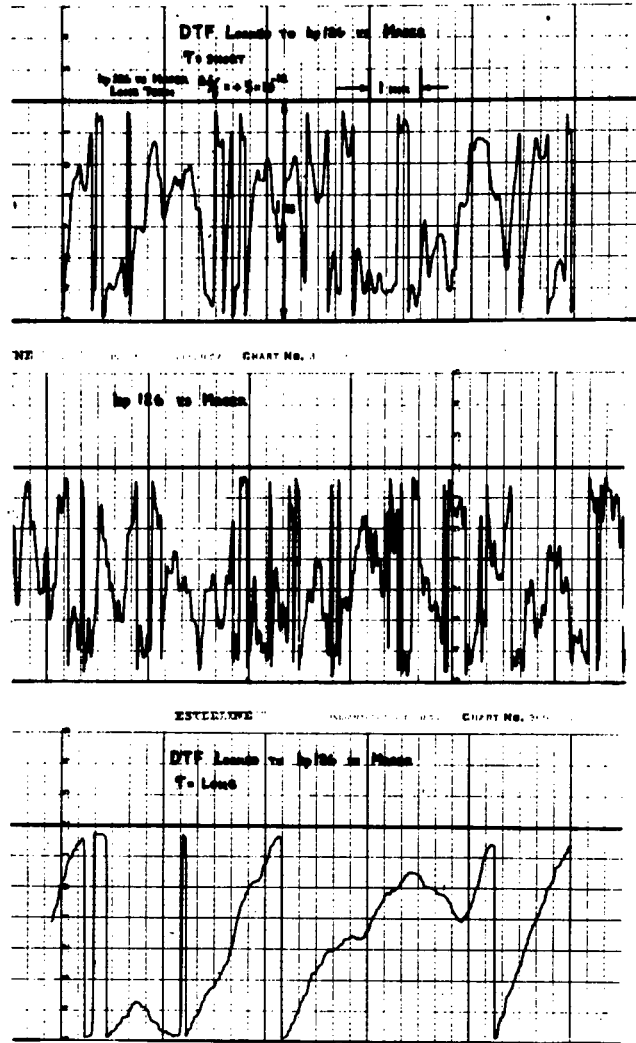

Figure 12. HP CESIUM BEAM STANDARD SER. NO. 126 VS  
NRL HYDROGEN MASER

## DISCUSSION

DR. WINKLER: I have no questions, but I would like to comment on your presentation. I think the development of the disciplined oscillator is to be extremely useful.

For our timing application, it might be cheaper to make the unit not serviceable at all--to have no connectors or modules in it--but to case the whole unit in epoxy or concrete and have a unit that would work 10 years without any serviceman ever looking at it; after that time you would throw it away. Even if it is a \$15,000 item it might be cheaper to do that in the face of ever-increasing costs of trained personnel and stockpiling replacement parts or modules, and of ever-increasing reliability problems with connectors, pilot lights, and other little things.