

THE INCREMENTAL PHASE SHIFTER AND PRN TIME TRANSFER

by

Dr. R.B. Kershner

Dr. Kershner is Space Development Department Head, Applied Physics Laboratory, Silver Spring, Maryland.

An experiment is being planned which will be run early next summer from a satellite under development by the Applied Physics Laboratory for the Polaris people of the Navy. The satellite is basically an experimental satellite to determine the feasibility of some of the techniques planned for an eventual second generation replacement of the current operational Transit navigation satellites at some future date. It is clear that technology will ultimately move to where the current Transit satellites leave something to be desired, although they are still meeting all existing requirements and are continuing to operate exceptionally well--much to the dismay of the current commercial producer, who never gets the opportunity to launch any because the ones that are up there keep running. The oldest of the current operational series was launched just over four and one-half years ago. Whereas no one intends to go up and shoot them down, the advance of technology will ultimately make them obsolete. The techniques that look applicable and desirable for an alternate second generation replacement are being studied with certain specific classified objectives in mind; however, these will not be discussed because of their classification. Certain other technical possibilities are being explored because of their potential usefulness in a second generation system.

The two pertinent techniques that will be discussed are, first, a method of recognizing arrival time of the signal with very much greater precision than is currently possible with the present Transit satellite and, second, a method of steering the frequency of the oscillator, which is still a good crystal oscillator, by command from the ground. In other words, this is a frequency synthesizer which is able both to move the frequency of the crystal oscillator to a given predecided value and to compensate for the aging of the crystal by incorporating a rate of change of frequency to stabilize the frequency at a standard value. If this is done in the satellite, there is no longer a need to treat frequency as another unknown in any computation so the interval over which it is necessary to observe the signals in order to get a good navigation fix can be reduced. This has obvious specific military interest, as well as general scientific interest.

The new satellite will retain the items shown in Figure 1 in the white boxes, which are currently in an operational Transit satellite. There are a crystal oscillator and a frequency multiplying chain which ultimately provide 400 megahertz and 150 megahertz as the two basic transmitted frequencies. A phase modulator will be used which is exactly like the present one to modulate the transmitted frequencies $\pm 60^\circ$ at a very low rate and provide coded information transmitted from the satellite. This coded information describes the satellite location--the ephemeris data. This information, together with the doppler shift observed on the signals at the receiving end, which has been corrected for refraction by the use of two coherent frequencies--150 megahertz and 400 megahertz--adds up to a precision fix on the part of the user.

The new devices that are being introduced into the satellite are shown in gray boxes. There are two devices: a pseudo-random noise modulation capability and an incremental phase shift synthesizer. The pseudo-random noise modulation capability consists of a code generator (in the largest box) driving phase modulators on each of the two frequencies.

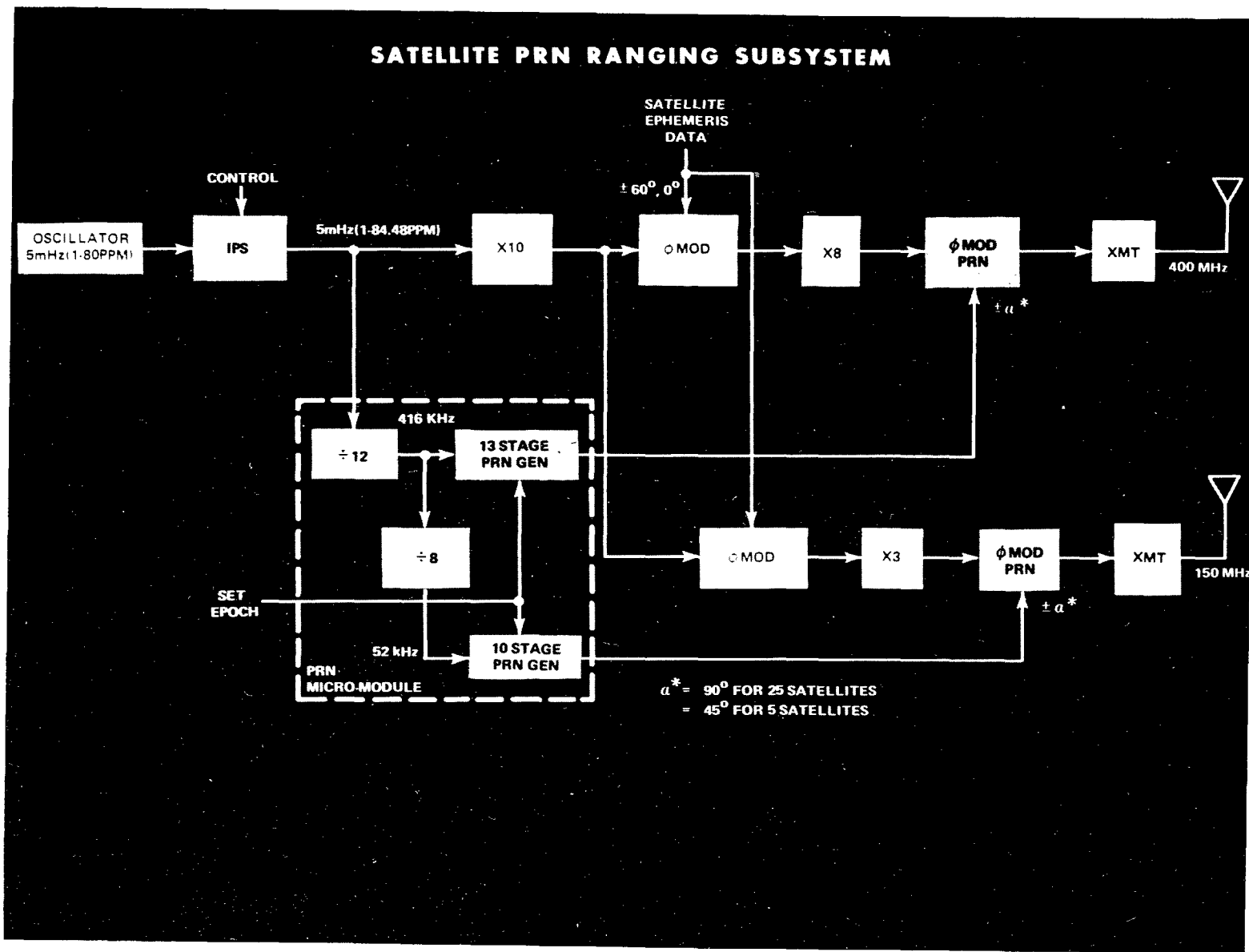

Figure 1. SATELLITE PRN RANGING SUBSYSTEM

This device puts a rapid phase modulation on the output of the signal, thereby effectively spreading the spectrum. It is a straightforward spread technique; a rather normal PRN method. This allows the recovery of the signal by reconstructing the phase modulation and the PRN code at the receiving end. Once synchronization is attained, there is an epoch recognition which uses statistics on a very large number of pulses rather than being dependent on the ability to recognize a single timing pulse with precision. This results in a precise synchronization of the ground receiver to the received signal. The other device that is being introduced is the incremental phase shifter (IPS). It is the PRN and the phase shifter that will be described with most of the discussion being on the incremental phase shifter. We are using one of the simplest ways to generate a PRN code.

1.0 PSEUDO RANDOM NOISE

As shown in Figure 2, there are four boxes, or stages, marked A, B, C, and D. At the start there are binary "ones" in each of them. On each clock pulse, whatever is in A goes to B, whatever is in B goes to C, and whatever is in C goes to D, but a zero goes into A if the contents of C and D are the same, and a one goes into A if the contents of C and D are different. So, on line D there are four ones, those would be the contents of A, B, C, and D, then each next digit is a 0. The entire code is generated with only four stages; this example would provide a 15-bit long PRN code in the sense that the correlation of the whole code with itself is 15 and repeats every 15 clock periods. However, the correlation of the code with any displaced-position translation of itself is near 0, namely either 1 or -1. There is roughly 1/15th of the auto-correlation with itself when the code is in any displaced position and this is the pseudo-noise characteristic. We generate a code of this nature but with many more bits, of course; this example is simply a very short code of the same type.

15 BIT PRN CODE

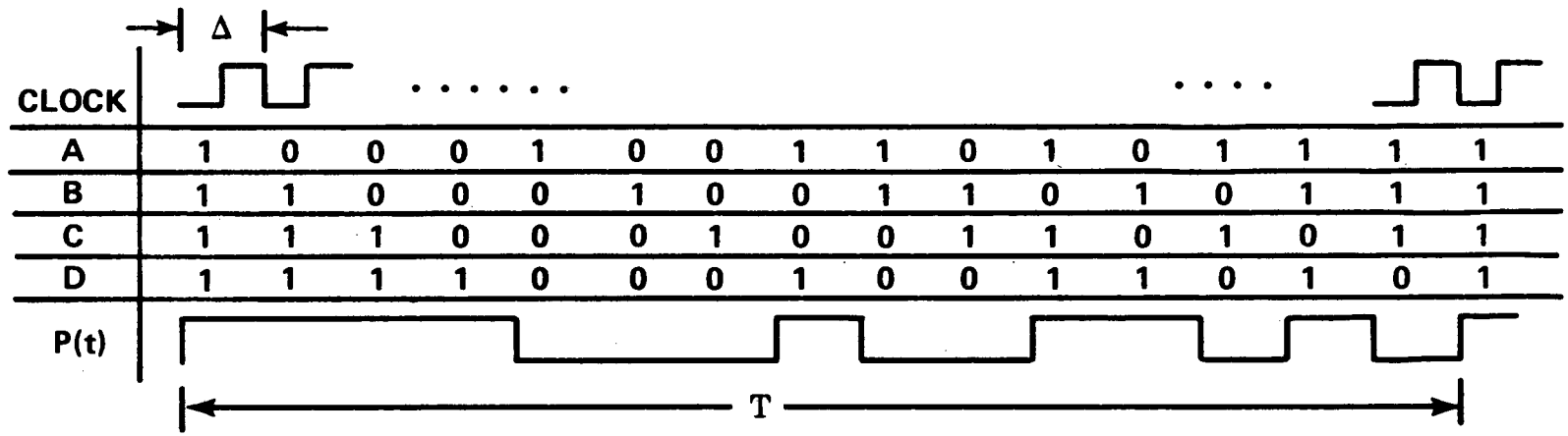
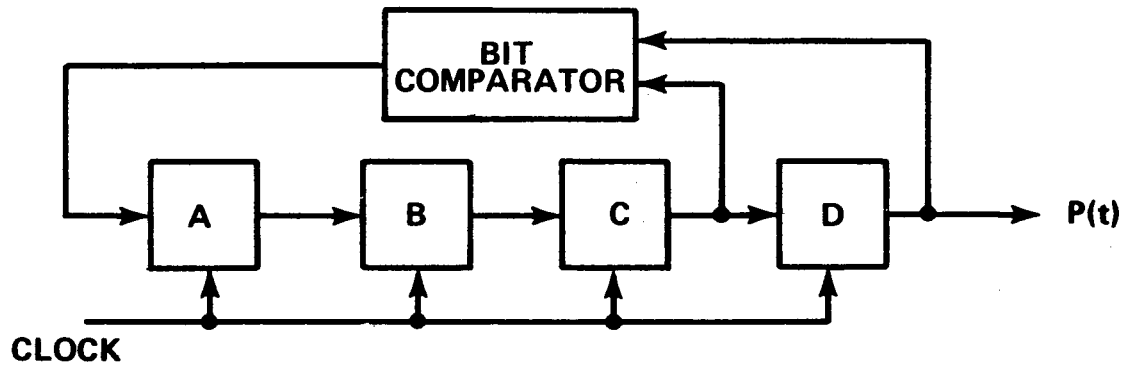

CORRELATION

																Σ
A TO B	+1	-1	+1	+1	-1	-1	+1	-1	+1	-1	-1	-1	-1	+1	+1	-1

Figure 2. 15-BIT PRN CODE

-27-

Figure 3 shows a PRN digital generator for use in the satellite. It should be noted that it is really a very small device.

Figure 4 shows the code generator together with the phase modulator that produces the actual phase modulation on the output signals. The unit shown is the one required for 400 megahertz, and, incidentally, it is flight hardware.

A similar device for the 150 megahertz is shown in Figure 5; it is really the only modification to a standard Transit satellite that is required in order to provide the random noise capability. There are two options, depending upon the amount of phase modulation that is to be introduced: when $\pm 90^\circ$ is introduced, the spectrum is totally spread and the carrier is completely suppressed; when a lower modulation level, such as $\pm 45^\circ$ is used, as in this first experiment, there is the advantage that half of the carrier is still there so that the receivers can still be operated in the old-fashioned way of tracking the carrier. At the same time, if one wishes to receive the PRN, it is also there and has half of the power in that mode. So essentially, the satellite radiated power is being split, half of it in the carrier, half of it in the PRN; and it can be used either way, which is extremely convenient for experimental purposes. It also enables one to simplify the synchronization or acquisition problem associated with the pseudo-random noise code.

Figure 6 shows the spectrum that is created with the protruding carrier 3 dB lower than it would have been if the PRN modulation were not used; also note that the power distributed by the PRN modulation is approximately 40 dB down from the coherent carrier. Therefore, unless you have the right PRN code, you do not know it is there at all.

Through funding support from the Naval Air Systems Command an AN/SRN-9 satellite navigation receiver is now being modified to recover the PRN code. A block diagram of the existing modified navigation receiver is shown in Figure 7.

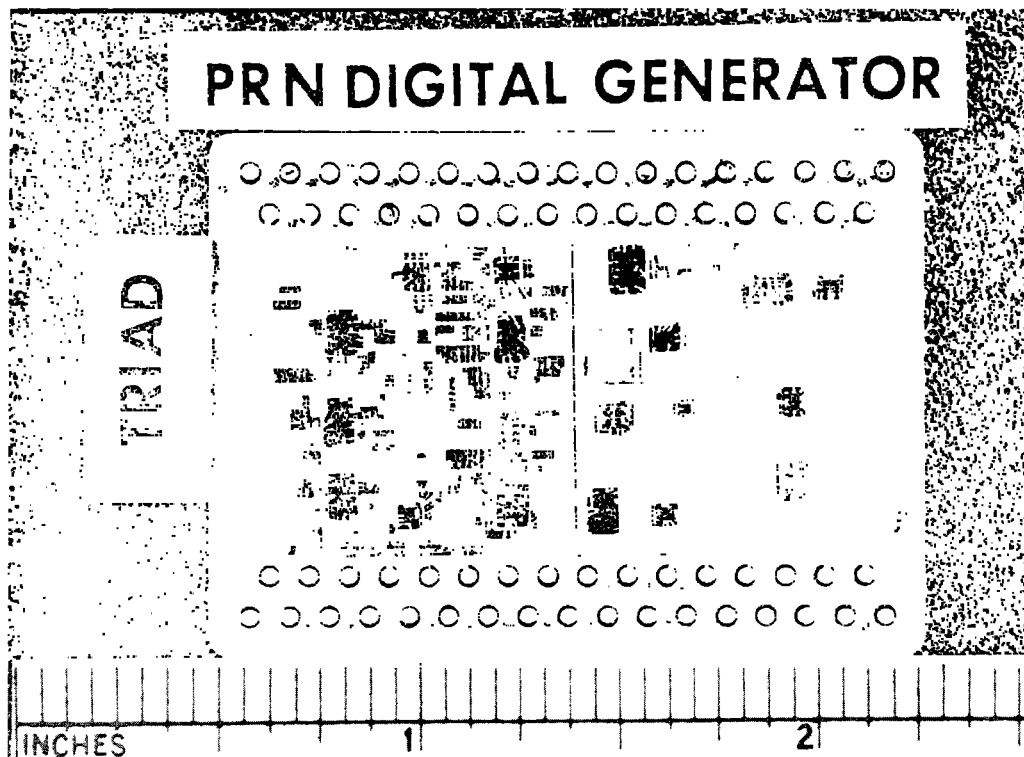

Figure 3. PRN DIGITAL GENERATOR

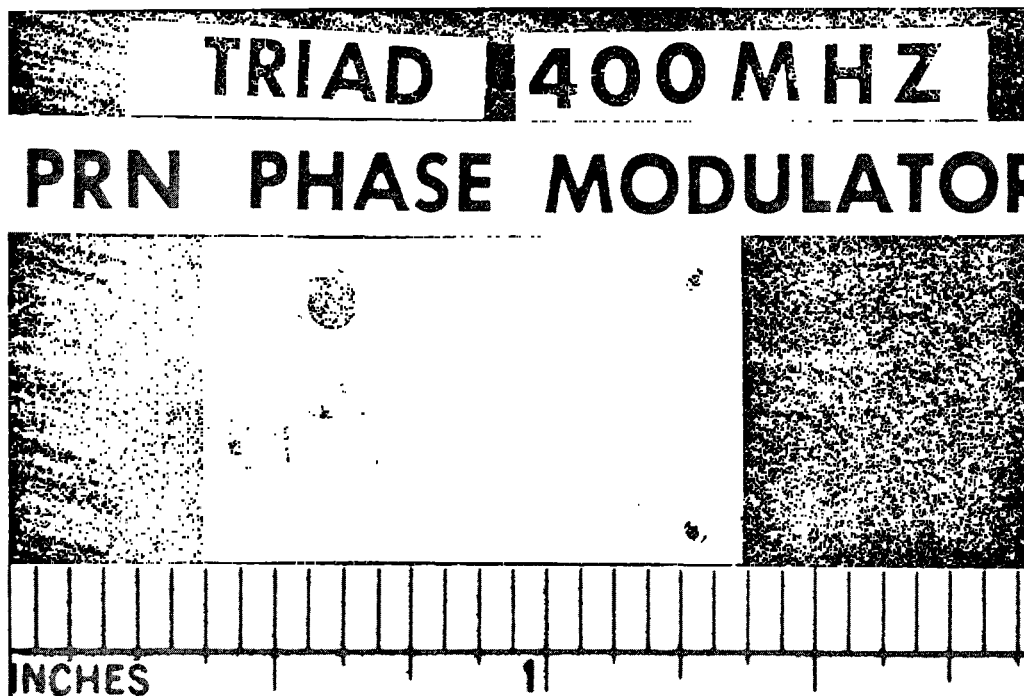

Figure 4. PRN PHASE MODULATOR

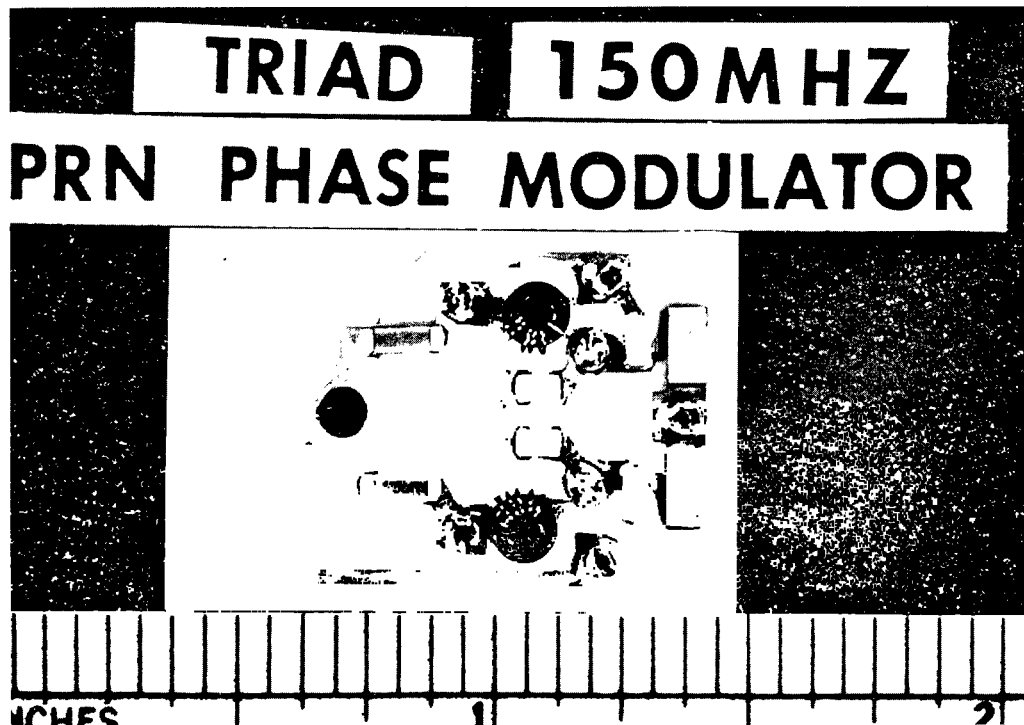

Figure 5. PRN PHASE MODULATOR (150 mHz)

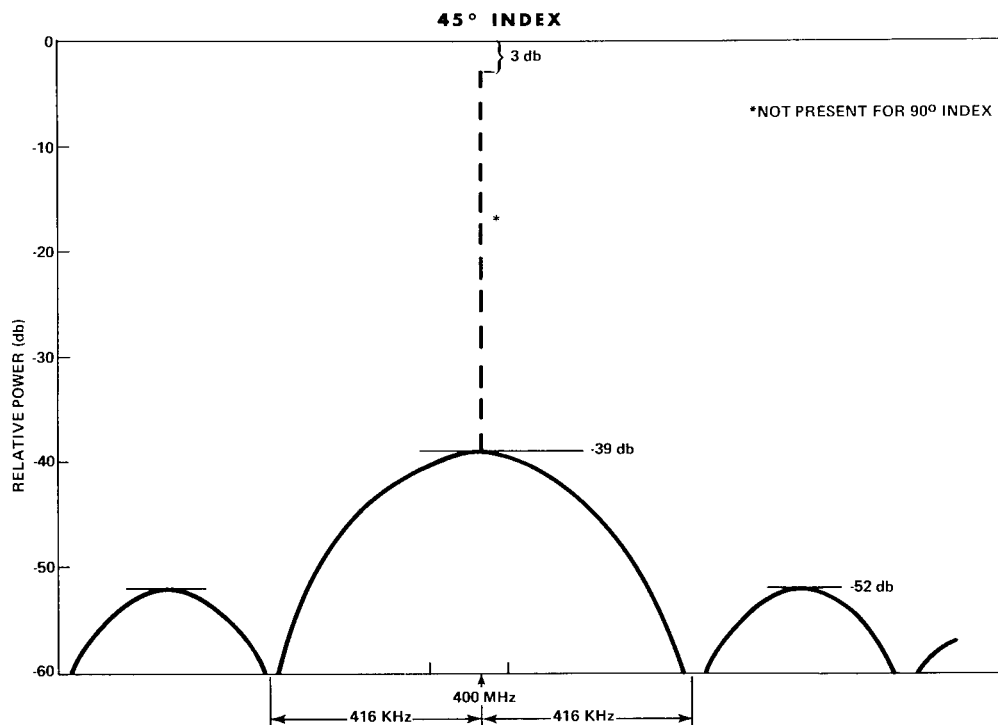

Figure 6. RF POWER SPECTRUM AFTER PRN MODULATION (45° Index)

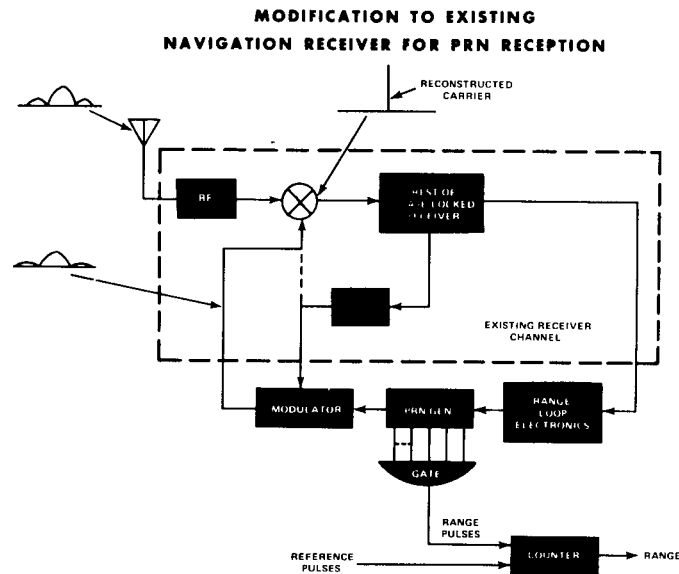

Figure 7. MODIFICATION TO EXISTING NAVIGATION RECEIVER FOR PRN RECEPTION

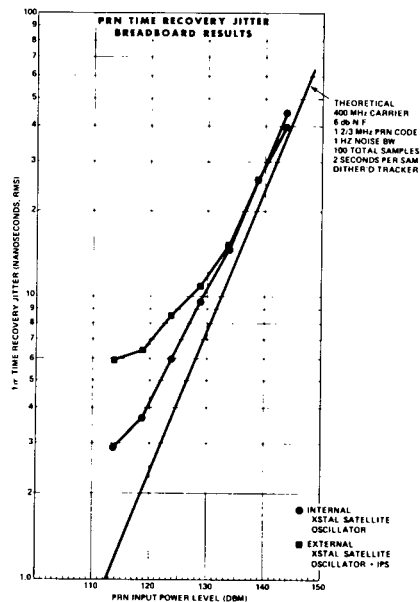

Figure 8. PRN TIME RECOVERY JITTER BREADBOARD RESULTS

Figure 8 shows results of some breadboard tests of the PRN equipment that has been built and incorporated into the experimental satellite which is called TRIAD, because it is made up of three interconnected bodies. The TRIAD satellite with PRN modulation allows the recovery and recognition of the epoch in the nanosecond region.

2.0 INCREMENTAL PHASE SHIFTER

The incremental phase shifter shown in Figure 9 is a somewhat larger device and is a means of synthesizing a frequency, or rather of shifting the frequency of a given oscillator by a small, carefully controlled amount; an amount that can be controlled digitally, so that one can send a digital signal to the satellite and say, "this is exactly the amount I wish this frequency shifted," and it will proceed to do that. It is done through the use of phase shifters operating on the 5 megahertz signal of the basic reference oscillator by taking out or putting in multiples of exactly 1.8° electrical degrees. There are two phase shifters working in cascade to make 200 steps per cycle of 5 megahertz; one has 25 steps of 1.8° or 1 nanosecond at 5 megahertz; the other, 8 steps of 45° or 25 nanoseconds at 5 megahertz. A digital word can control the rate at which these advance or retard the phase and, by putting in proper satellite remote command, and can make anything from extremely small, extremely slow frequency changes to very substantial ones.

Figure 10 shows these 1.8° steps for a total of 200 of them to complete one cycle and the continuation of the process from cycle to cycle.

Figure 11 shows how time can be controlled by steering the rate of the oscillator. If one is counting out this oscillator and putting out time ticks, and if the time ticks are not running at a satisfactory rate, one can simply steer the frequency of the oscillator to a point which produces time ticks at the rate desired. It should be noticed that the variations in time provided by this method of frequency correction are in the 20 picosecond

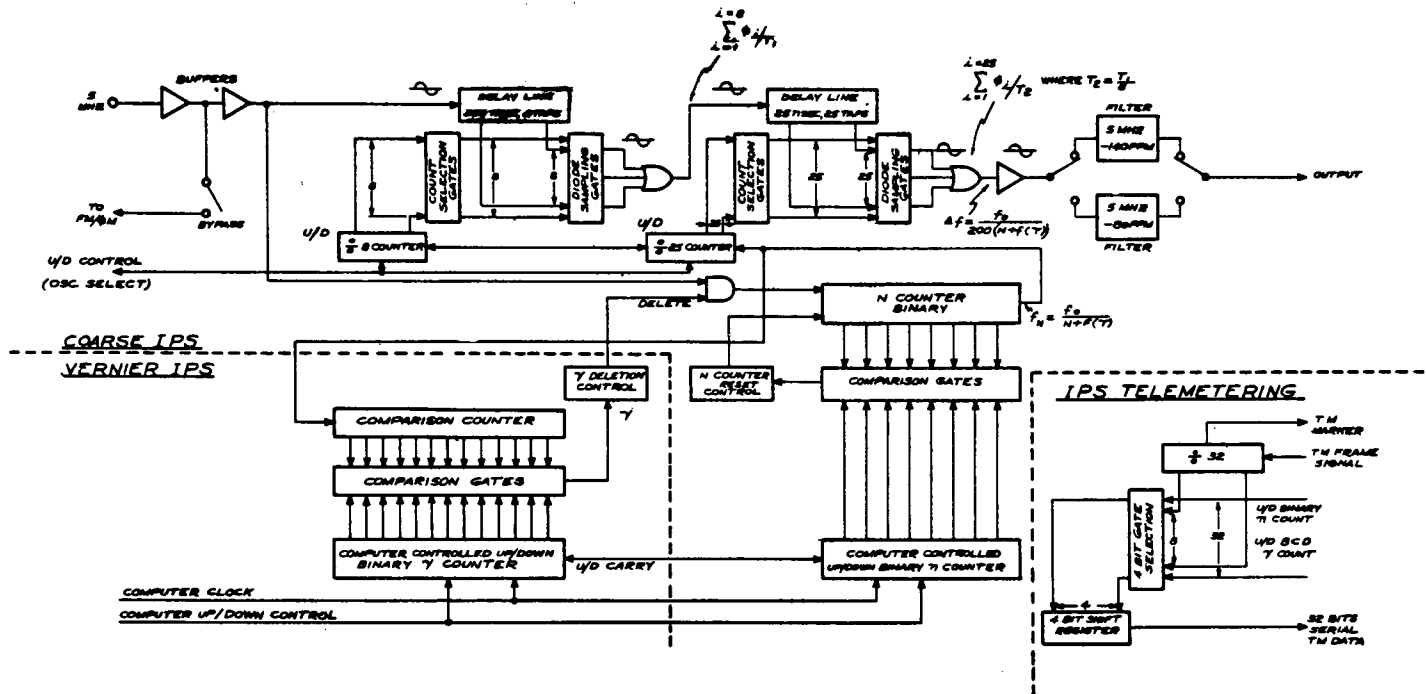

Figure 9. INCREMENTAL PHASE SHIFTED SYSTEM BLOCK DIAGRAM

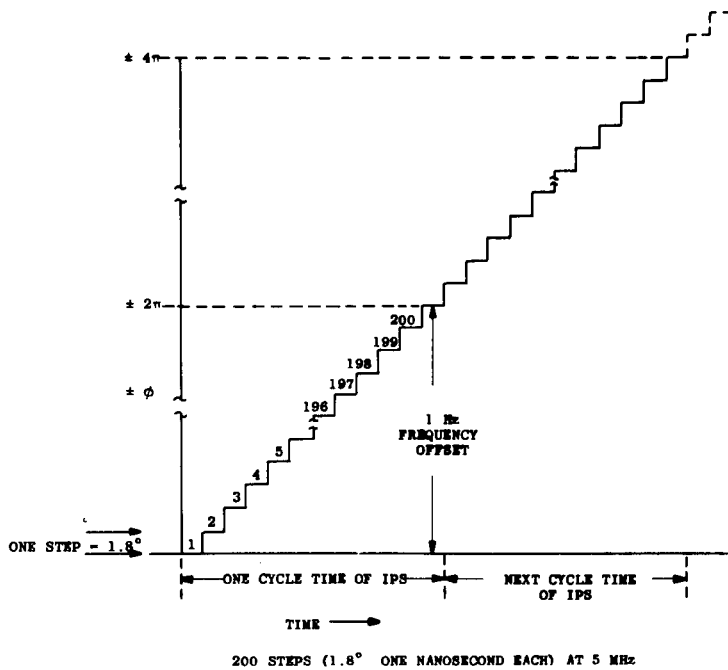

Figure 10. IPS PHASE STEPS

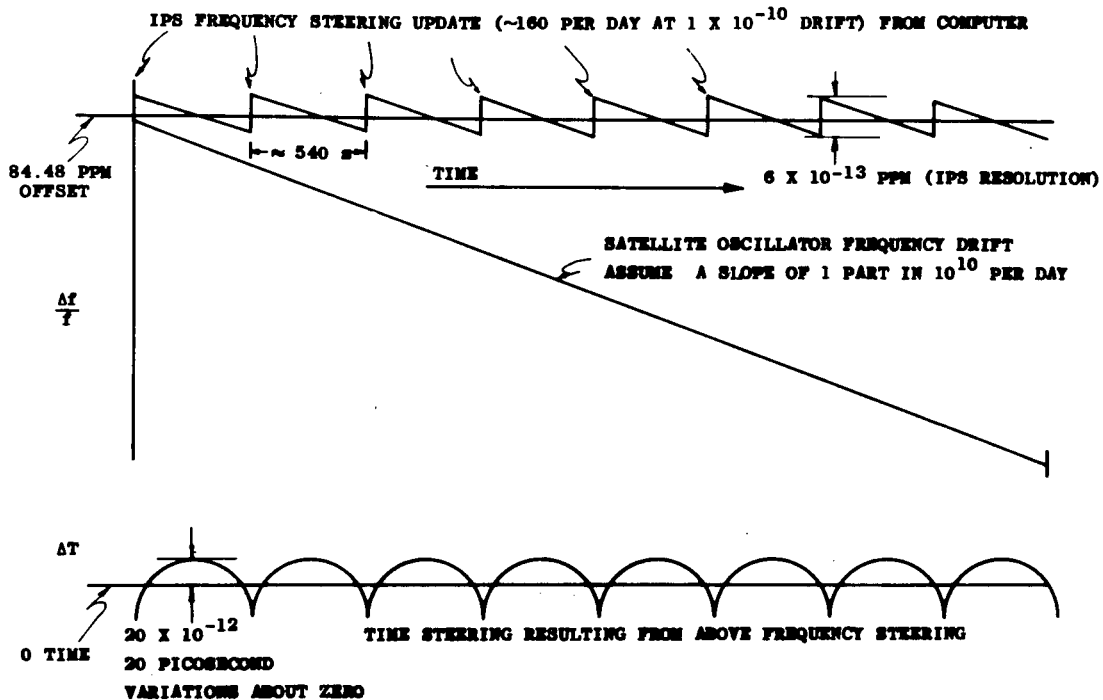

Figure 11. IPS FREQUENCY AND TIME STEERING

level, so that for time correction to the nanosecond level, this is a completely acceptable method of operation.

The IPS specifications are as follows:

Output frequency

5 megahertz - 145.51 ppm adjustable in steps of
6 parts in 10^{13} .

5 megahertz - 84.48 ppm adjustable in steps of
8 parts in 10^{13} .

Epoch adjustment precision < one nanosecond.

Power - 1.3 watts

Weight - 0.7 pounds

Volume - 42 cubic inches

We have two different offsets for the 5 megahertz; one offset provides the operational frequency and one is different from the operational frequency. The offset used depends on whether the satellite is used to provide navigation service or whether it is used in an experimental mode. There are slightly different resolution capabilities depending on the output frequency desired.

Figure 12 shows the breadboard which has been operating 6 to 8 months at the laboratory. Some of the experimental results are shown.

Figure 13 is a diagram of the IPS package; a photograph was not available but it will be a box of about 4 inches by 7 inches by 1-1/2 inches in the TRIAD satellite.

In order to find out its basic performance, it is necessary to know the magnitude of noise generated within the device itself. To measure the noise level, we essentially beat a cesium standard oscillator against itself by operating two clocks from the same standard. One clock obtained its signal straight through a divider chain; the other went through the IPS and a separate divider chain. Therefore any noise produced by the IPS would show up on that output and the time differences should differ from 0 by the

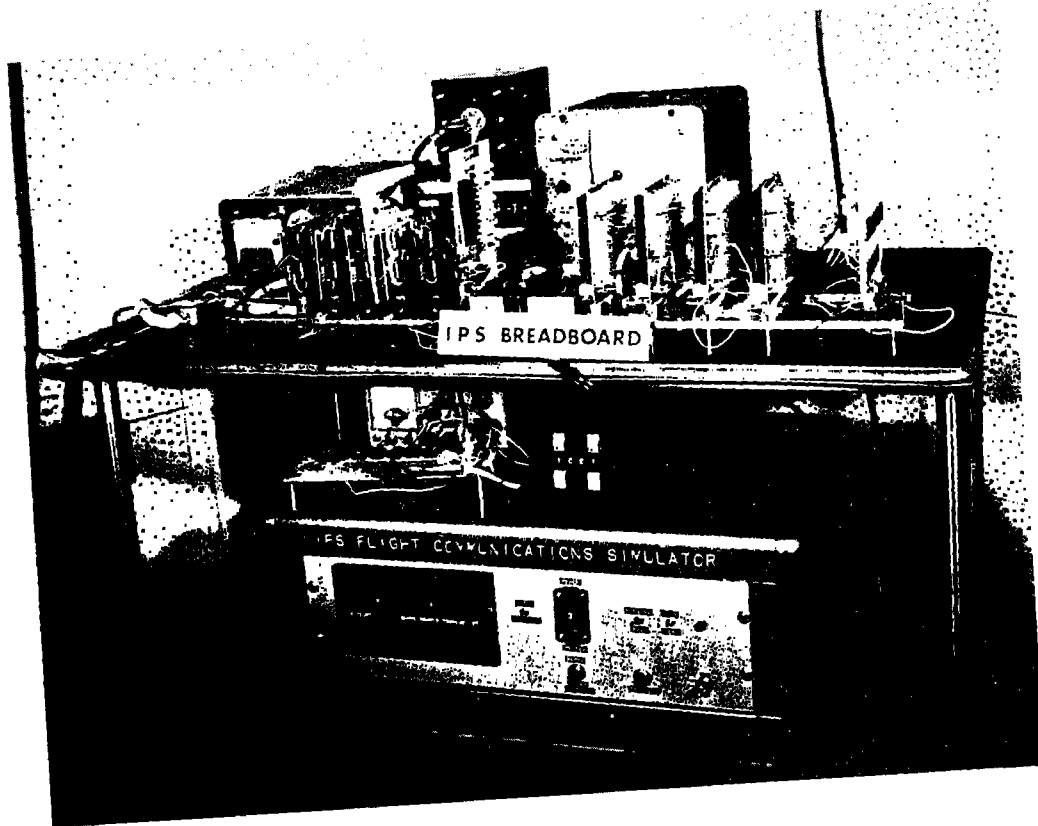

Figure 12. IPS BREADBOARD

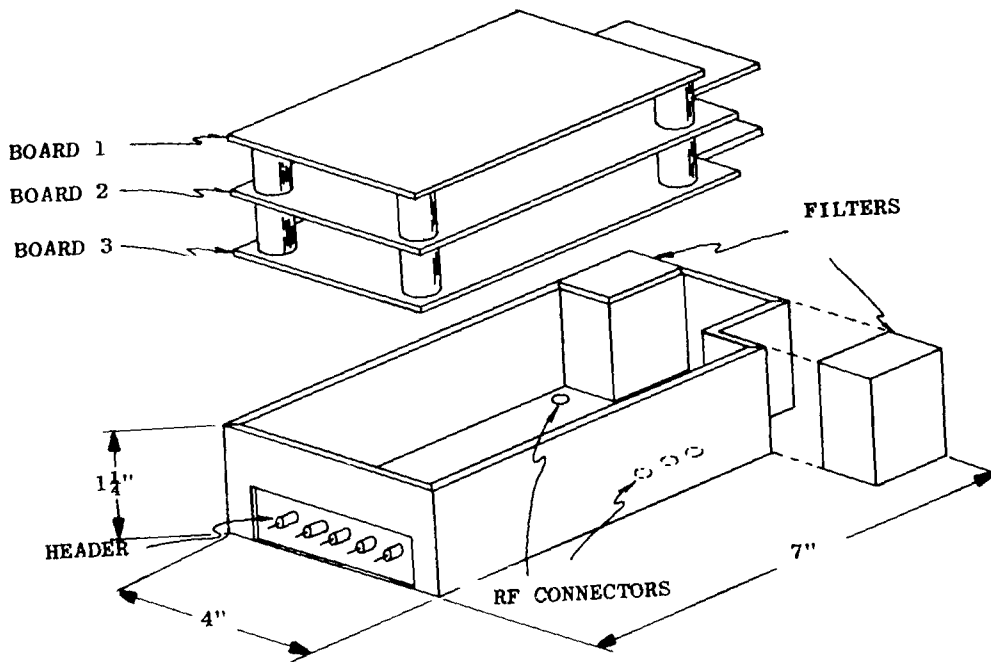

Figure 13. IPS PACKAGE

amount of the noise input of the IPS unit. The time differences were measured by a computer counter.

It can be seen in Figure 14, on a scale on which 10 nanoseconds is shown as a fairly substantial number, that the total IPS instrument noise is certainly well under a nanosecond.

Figure 15 shows the basic minimum adjustment step of the IPS; that is, time of error of ± 50 nanoseconds a day. It can be seen that the instrument noise level is so far under the basic minimum adjustment step that instrument noise is not a problem.

The next thing tried was to actually correct for the drift of a crystal oscillator-driven clock relative to a clock driven by one of the cesium standards by inserting the appropriate rate in an IPS unit to modify the crystal oscillator frequency. Figure 16 shows the time comparison, which was well under the 100 nanoseconds level, but due to the non-predictable frequency drift rates of the crystal oscillator, the time error could not be kept under 50 nanoseconds. This is inherent in what that particular crystal oscillator was able to do. It should be noticed that the period of time was about 3 days; these time errors are fairly small departures from a constant time rate, but they are not extremely rapid in fluctuation.

The same sort of test was made using two different cesium standards-- Serial #121 and Serial #450. First they were directly compared against each other to see what the basic difference in their offsets and rates were. Figure 17 shows that the difference in frequency resulted in a time error rate of approximately 30 nanoseconds an hour. You will notice the scale is pretty large; the total scale is a full microsecond.

An attempt was then made to synchronize by putting in a 30 nanosecond per hour correction with the incremental phase shifter. In Figure 18, the scale is changed so that instead of a microsecond, 100 nanoseconds is full scale, and on this scale a fairly substantial jitter can be seen. However, this is not nearly as much as was shown by the crystal oscillator

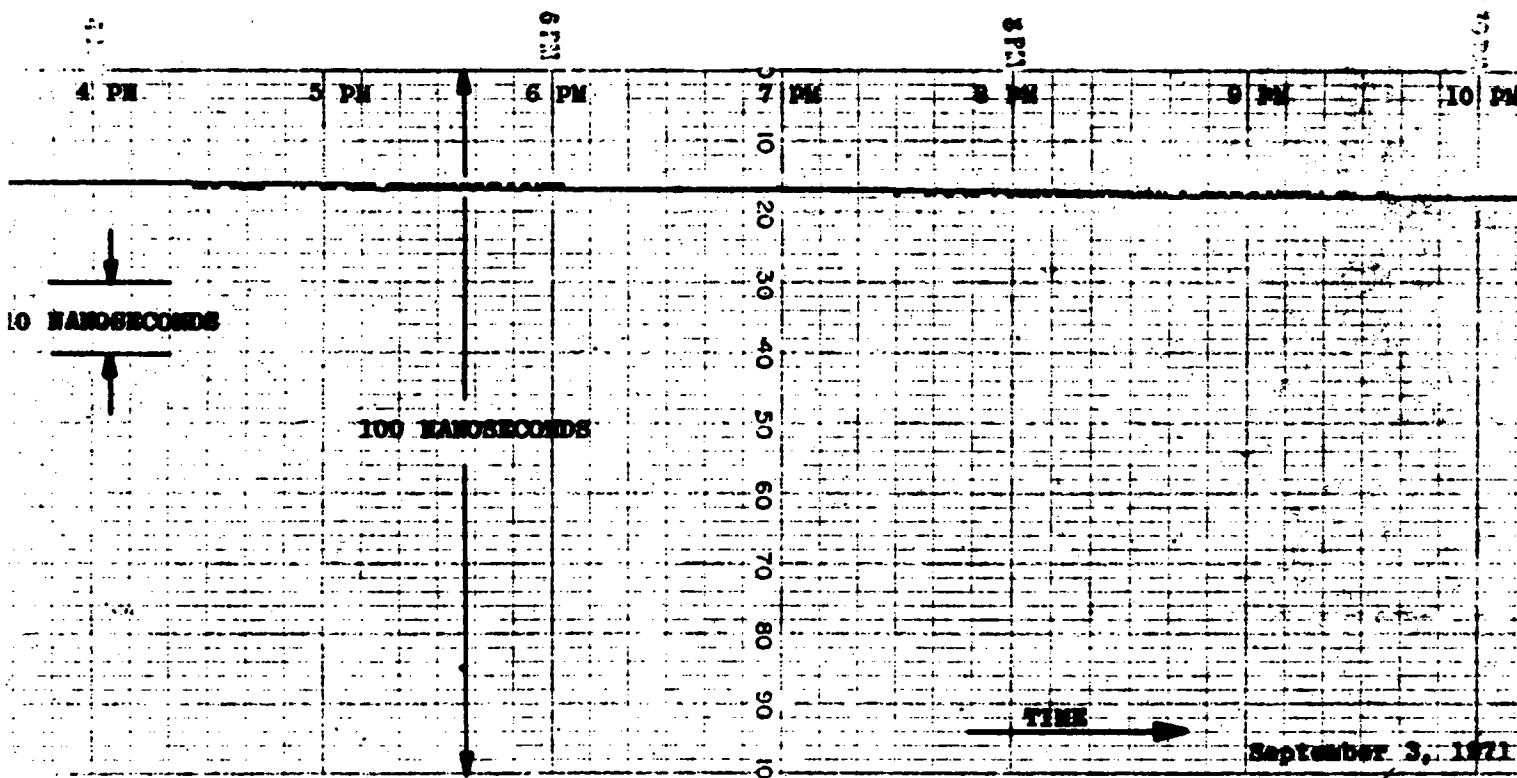
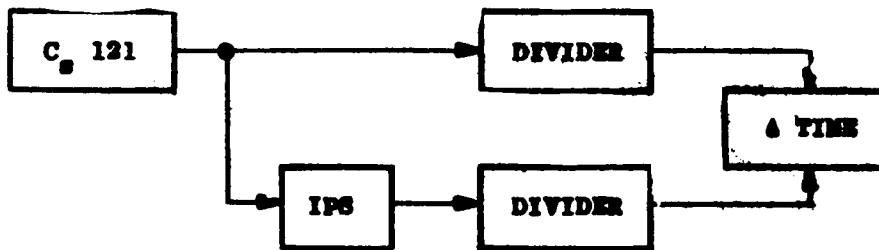

Figure 14. CESIUM (SN 121) VS. IPS (OFFSETTING CESIUM (SN 121))
IPS INSTRUMENTATION NOISE

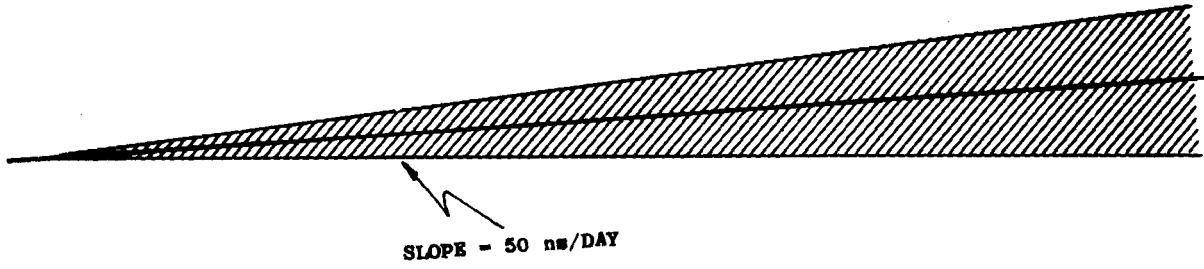

Figure 15. MAXIMUM TIME ACCUMULATION DUE TO SMALLEST INCREMENT OF IPS

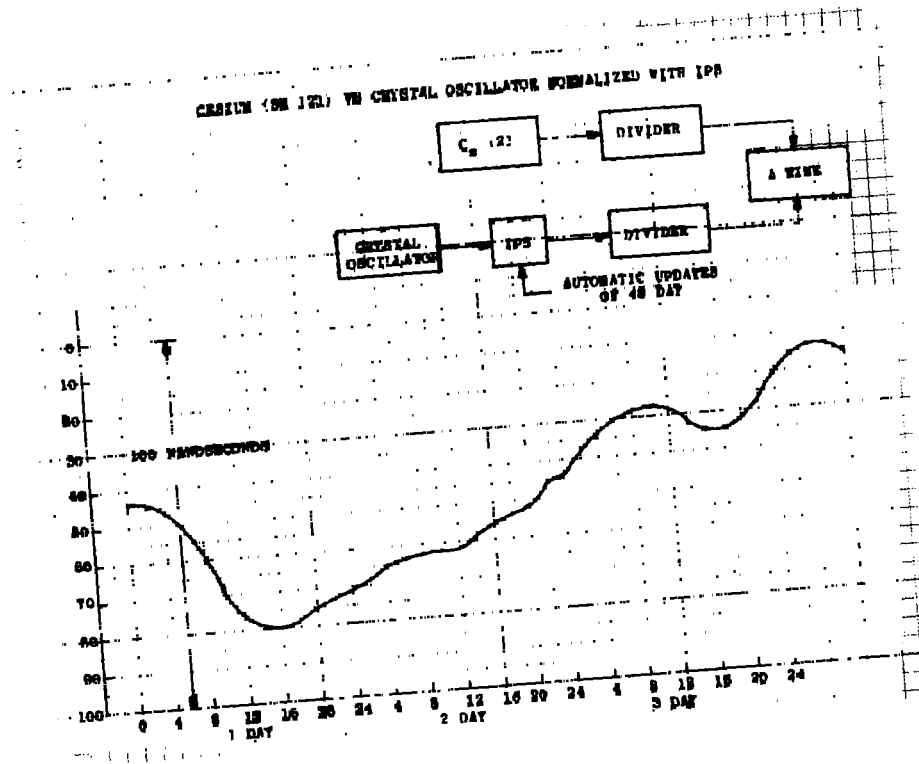

Figure 16. CESIUM (SN 121) VS. CRYSTAL OSCILLATOR NORMALIZED WITH IPS

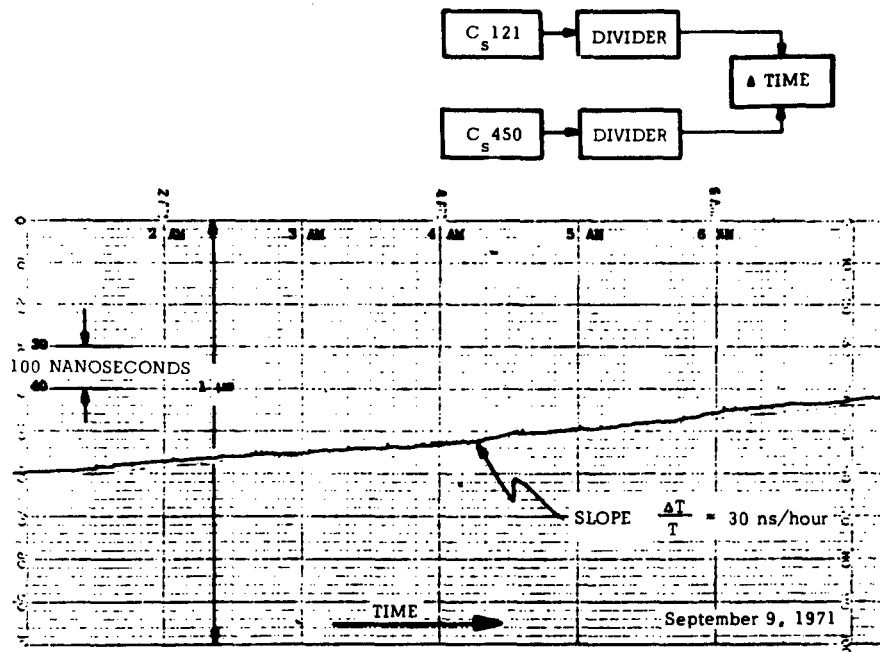

Figure 17. CESIUM STANDARD (SN 121) VS. CESIUM STANDARD (SN 450)

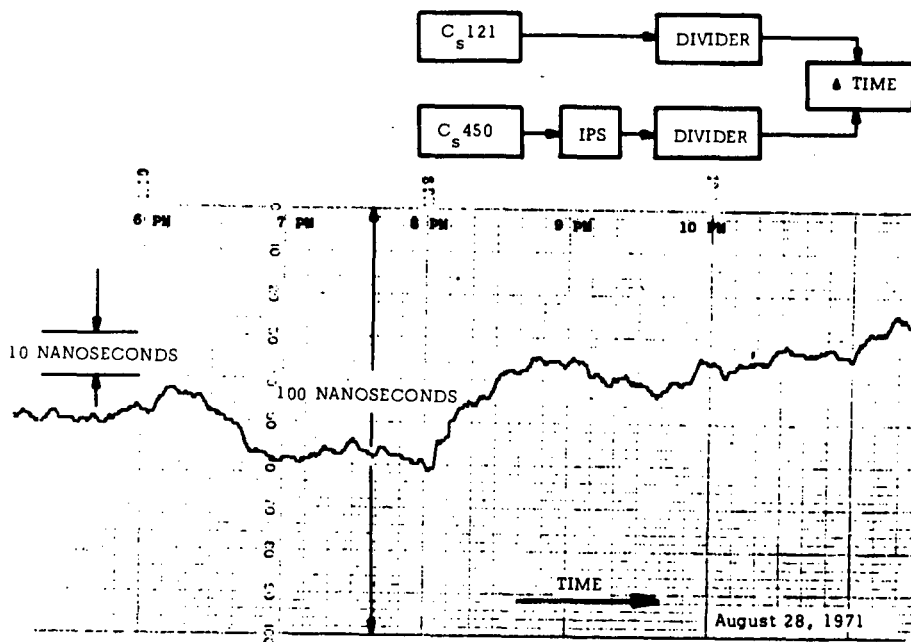

Figure 18. CESIUM (SN 121) VS. CESIUM (SN 450) IPS CONTROLLED - WORST CASE

where it was necessary to go to a factor of 10 larger scale. In Figure 18, the data shown are for the worst period time observed for a period of about 4 hours on August 28.

At other times, results were observed as good, as shown in Figure 19, in the behavior of two cesium standards. One cesium had been moved in frequency by IPS to agree with the other cesium. For a period of 4 hours they kept time errors at about the nanosecond level.

A summary of what seems to have happened so far with the use of the incremental phase shift oscillator and PRN time recognition at the laboratory is shown in Table 1. We can steer the frequency of a crystal oscillator to provide a clock correct to better than 100 nanoseconds over 3 days. We know that the basic instrumentation noise of the IPS itself introduces a time error of approximately 3×10^{-10} seconds, on a short-term basis, and that the cumulative time error is less than 50 nanoseconds per day for a specific fixed frequency setting of IPS. IPS can correct the drift rate of a crystal oscillator to the degree that the drift can be predicted. An improvement in the effective drift rate of 50:1 has been demonstrated.

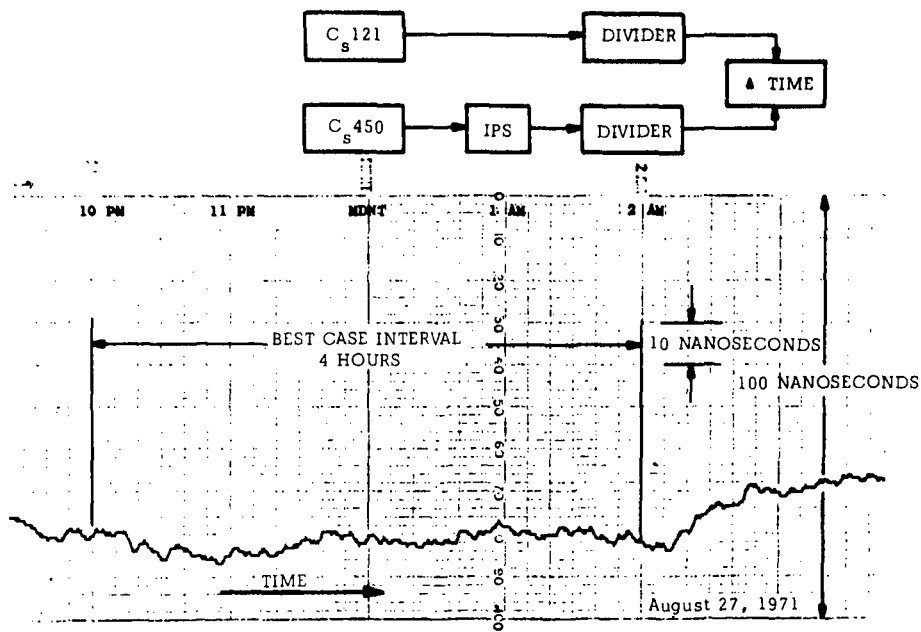

Figure 19. CESIUM (SN 121) VS CESIUM (SN 450) IPS CONTROLLED - BEST CASE

Table 1. APL TIME NORMALIZATION CAPABILITY

1. CESIUM STANDARD AT APL NOW DRIFTS AT 864×10^{-9} sec/day.
2. DEMONSTRATED: CRYSTAL OSCILLATOR FREQUENCY STEERED WITH THE IPS BREADBOARD TO THE C_s STANDARD TO $< 100 \times 10^{-9}$ sec. OVER 3 DAYS. CRYSTAL DRIFT RATE OF $> 6 \times 10^{-11}$ /day or 5×10^{-6} sec/day (50:1 IMPROVEMENT).
3. DEMONSTRATED: IPS INSTRUMENTATION NOISE $\approx 3 \times 10^{-10}$ sec. SHORT TERM JITTER.
4. CUMMULATIVE TIME ERROR OF IPS FROM MINIMUM STEP ADJUSTMENT; 50×10^{-9} sec/day FOR FIXED FREQUENCY IPS SETTING.
5. CUMMULATIVE TIME ERROR $< 1 \times 10^{-9}$ sec/day BY DUTY CYCLE OF IPS LEAST SIGNIFICANT BIT.
6. IPS CAN CORRECT OSCILLATOR DRIFT TO THE ABILITY TO PREDICT THE DRIFT RATE. 50:1 HAS BEEN DEMONSTRATED.

DISCUSSION

DR. WINKLER: Dr. Kershner, do you anticipate any difficulties for the coming changeover in frequency on 1 January because you are not going to have these phase shifters in service yet, and you will have to tune your crystals?

DR. KERSHNER: No basic technical difficulty, no. There is still some discussion with the Navy Astronautics Group who run the current Transit program as to exactly how they are going to do it. There are several possible ways. Technically there is no reason for having any trouble. Because human beings are involved, there is a question, however, whether or not everything will get done right, and on time. But it is possible to cope with the problem. The only real trouble is tracking over periods of time for which data are obtainable before and after.

MR. LIEBERMAN: Do you anticipate much degradation when it is in the satellite?

DR. KERSHNER: In general, they behave better in the satellite than they do on the ground because of the much nicer and more controlled environment. We have seen no sign of real degradation. Generally, after they've been in orbit for about 4 or 5 days, they settle down very nicely and you get a very calm and rather steady and predictable aging rate which holds quite well. We do, once in a while, see a sudden shift, one part in 10^{11} , and it just happens and nobody knows why but then it goes on as before. This has happened on not most, but many, of the oscillators in satellites. That's the only freakish performance; it's very rare and very intermittent. Generally they behave better than on the ground.

MR. CHI: I have heard many times that the crystal oscillator behaves better in space. Do you have any explanation or any simulation results in the laboratory which could account for it?

DR. KERSHNER: I have no proof of this. I think a strong factor is the fact that you simply cannot get a human being within 400 miles of it. Also, the basic environment in a satellite is very carefully controlled. It's easy to have extremely good temperature control and your power conditioning is under quite good control and the situation is totally repetitive. If it survives a month or so, it has seen essentially everything it's ever going to see. There are more sources for power transients, for temperature changes, and so forth in the typical laboratory than there are in the satellite. It's easier to realize a good thermal design in the satellite than in the laboratory. A very good vacuum for a multilevel vacuum system is readily available in the satellite.

MR. CHI: You don't feel that the zero gravitation field might have some effect in relaxation of the crystals?

DR. KERSHNER: The fact that the vibration level is essentially zero in the satellite certainly cannot hurt. I think if you had a steady 1 G you'd be just as well off as having a steady zero. In the laboratory you have 1 G \pm some fraction of vibration that cannot be totally isolated, and that surely isn't as healthy an environment as a steady acceleration of zero or any other amount. The satellite is just a very comfortable place.