

# TCO100

**STABILIZED OSCILLATOR**

**AND**

**TIME CODE GENERATOR**



## TABLE OF CONTENTS

DISCLAIMER .....	1
GPS ADVISORY NOTICE.....	1
CONTACT INFORMATION.....	1
FEATURES .....	2
INTRODUCTION .....	2
Precision Clock .....	2
TIME CODES SUPPORTED.....	2
SMPTE.....	2
IRIG-B .....	3
OPERATION.....	3
GPS200 Reference .....	3
SETUP/OPERATION VIA FRONT PANEL BUTTONS .....	3
Front button operation.....	3
SETUP/CONFIGURATION VIA INTERNAL SWITCHES.....	3
Access to PC Board.....	3
Setup and I/O Options .....	4
Time Code Generation .....	5
Time Code Routing Configuration .....	5
Control Input Wiring Diagram .....	6
Control Output Wiring Diagram .....	6
Control Output Adapter & Cable .....	6
Available Output Signals.....	6
TCO100 – GPS200 Interconnect Cable .....	7
Simplified GPS to TCO Wiring Diagram.....	7
RS-232 INTERFACE .....	7
PROBLEMS - TROUBLESHOOTING .....	7
SPECIFICATIONS.....	8
Time Code Output.....	8
Timing Characteristics .....	8
PPS Output.....	8
Alarm Output.....	8
Front Panel Indicators (LEDs) .....	9
Remote Interface .....	9
Physical .....	9
Environmental .....	9
Power Supply Requirements .....	9
Battery Operation.....	9
NOTES .....	9
Note 1.....	9
Note 2.....	9
OPTIONS & RELATED HARDWARE .....	10
LIMITED WARRANTY .....	11
Hardware Service.....	11

## **DISCLAIMER**

The information contained in this document is subject to change without notice.

Masterclock, Inc. (hereinafter MC) makes no warranty of any kind with regard to this material, including, but not limited to, the implied warranties of merchantability and fitness for a particular purpose.

MC shall not be liable for errors contained herein or for incidental or consequential damages in connection with the furnishing, performance, or use of this material.

MC is not responsible for legislative changes to the Daylight Saving Time (DST) rules, nor to the systems relying on accurate time which may be affected by such changes. Issues related to legislative changes to the DST rules are not covered under the Masterclock, Inc. limited warranty.

See limited warranty information starting on page 12.

## **GPS ADVISORY NOTICE**

### **CONCERNING GPS SATELLITE SYSTEM AND THE GPS200 / TCO100 TIME CODE GENERATOR COMBINATION**

Depending on many factors beyond the control of Masterclock, the signals that are received from the GPS Satellites are subject to interference, fading, satellite failure and other influences *that could cause* the GPS200 and hence the TCO100 which may be synchronized to the GPS200 to generate erroneous time and/or date information and, under some conditions, *could prevent* it from generating a time code signal and or cause it to generate an erroneous time code signal.

It is the responsibility of the user to determine the adequacy and suitability of this device for the intended use.

## **CONTACT INFORMATION**

Masterclock Inc.  
2484 W Clay St  
Saint Charles, MO 63301 USA

Tel: +636 724 3666  
Fax: +636 724 3776

Email:  
[sales@masterclock.com](mailto:sales@masterclock.com)  
[support@masterclock.com](mailto:support@masterclock.com)

Web: <http://www.masterclock.com/>

## **FEATURES**

- Interfaces to Masterclock GPS200 master clock system for GPS-disciplined operation
- Integrated precision battery backed-up real-time clock
- Front panel LED time display
- Time/date configurable by front-panel buttons
- Time zone and daylight savings time adjustments available for generated time code
- Date encoding support for SMPTE and IRIG-B time code formats
- RS-232 control of time, time zone, and other parameters

## **INTRODUCTION**

Although the TCO100 is designed to work primarily as a companion to the GPS200 master clock generator/receiver, it will function as a high quality, standalone source of precision time code, time interval. When combined with a GPS200 master clock receiver the TCO100 will deliver accurate & precise time virtually anywhere in the world. When operated as a stand-alone oscillator/time code generator source the internal clock can be set with front panel switches or via RS232 control and will maintain stable time and frequency for long periods of time without further intervention or calibration.

## **PRECISION CLOCK**

The basic TCO100 is supplied with a precision temperature compensated crystal oscillator (TCXO) and clock generator that will maintain a time accuracy of  $\pm 1$  min per year over a temperature range of 0 – 40° C when used in standalone operation. When installed in a regulated temperature environment (office/lab) , configured with a GPS reference signal from a GPS200, and allowed to stabilize for several days without power interruption, the time drift is reduced by an order of magnitude and will approach  $\pm$  several seconds per year (when GPS reference is lost). See notes 1 and 2 under the specification section.

When the unit is connected to a GPS200, the internal clock is automatically calibrated each second to an absolute accuracy of  $\pm 10$  ms – typically  $< 5$  ms. Upon loss of the GPS signal the unit will switch to the internal clock as a reference and continue outputting time code with the above described specifications.

If the GPS reference signal is lost, then the calibrated TCXO will assume control at the last calibrated point and typically provide time with a reduced drift of (typically) less than a few seconds per year. Upon regaining a reference signal from the GPS200 the unit will automatically resynchronize to the GPS.

Using state-of-the-art technology, the TCO100 ensures excellent accuracy and reliability - at an affordable price.

## **TIME CODES SUPPORTED**

The TCO100 supports configurable output of three major TC formats. All of these TCs work well and all are in use in thousands of locations throughout the world. If your operation, installation, or facility is currently using a particular type of TC it is probably best to continue using the same TC.

## **SMPTE**

Defined by the Society of Motion Picture and Television Engineers. It is available in frame rates of 30, 25, and 24 frames second. The TCO100 supports all three formats.\* All formats of SMPTE time code generated by the TCO100 carry full date information in the user bits as defined by Leitch Inc.

*\* The TCO100 does not support generation of SMPTE drop-frame time code. Masterclock, Inc. does not provide products with, or support for, drop-frame capability.*

## IRIG-B

Defined by the Range Commanders Council, U.S. Army White Sands Missile Range. The format is used by military, government, power industry, and many other commercial and industrial applications. The TCO100 generates IRIG-B in both a 1kHz modulated and unmodulated (pulse-width coded) format. All formats of IRIG-B time code generated by the TCO100 carry time of year information BCD (binary coded decimal). All formats of IRIG-B time code generated by the TCO100 also carry extended year/date and time zone information in the control functions (CF) as defined by the IEEE 1344 specification.

## OPERATION

When the TCO100 is powered on, it will begin generating time relative to the internal real-time clock, with any configured time zone and daylight savings time features applied.

## GPS200 REFERENCE

If the TCO100 has been attached to a Masterclock GPS200 master clock system, the TCO100 will begin disciplining itself to the master clock as soon as it achieves a satellite fix. If the GPS master clock later loses its satellite fix, the TCO100 will revert back to real-time clock referenced operation until the GPS fix is regained.

## SETUP/OPERATION VIA FRONT PANEL BUTTONS

### FRONT BUTTON OPERATION

The front panel contains 3 buttons to control time and date setting, and a 6-digit, 7-element LED display. The time and date can be manually set using the MODE, UP, and DOWN buttons. Time is displayed as HH, MM, SS (24-hour clock) and date is displayed as MM, DD, YY.

Pressing MODE once causes the hour digits to flash. Use the UP or DOWN buttons to change to the correct hour. When the correct hour displays, press the MODE button once to display the minutes. Again use the UP or DOWN buttons to change the minute display to the desired time. Continue pressing the MODE button and using the UP and DOWN buttons to set the Seconds, Month, Day and Year. Press MODE one final time to complete the setup process.

Only time information will be displayed on the front panel, and date can be viewed by pressing the MODE button. Time Code will be generated based on the time set in the TCO100 until a valid time code input signal is received from a GPS200.

## SETUP/CONFIGURATION VIA INTERNAL SWITCHES

### ACCESS TO PC BOARD

In order to gain access to the pin jumpers and switches referred to below, it is necessary to remove the case from the TCO100. This is accomplished as follows:

First disconnect the power and any cables from the unit. Even though the highest voltage inside the TCO100 is 12 - 28 VDC (which is generally not dangerous to touch), accidentally shorting a trace or wire inside the unit with power-on could destroy or damage any one of the extremely sensitive electronic modules. Accidentally shorting a wire or trace or subjecting the unit to a static discharge, even for a very small fraction of a second, can destroy these modules. *Such damage is not covered by the warranty.*

Remove the two outside Phillips screws in the rear panel (this is the end with the power and DB-9 connectors). Holding the case of the unit in one hand, slide the rear panel assembly outward from the rear. The entire rear panel assembly and PC board will slide out.

As was mentioned above, the PC board is sensitive to any electrical signal including static discharge. Do not touch the PC board with any external wiring and, whenever possible, handle the unit by the rear panel or on the edge of the

PC board as you would a Compact Disc. When not changing the jumpers or switches always keep the PC board installed in the case.

When reassembling the unit, ensure that the PC board is properly fitted into the slots in the base of the chassis. When properly inserted, the PC board and rear panel assembly will slide easily into the case, no force is necessary. The warranty does not cover damage caused to the unit while removing or reassembling the PC board.

**SETUP AND I/O OPTIONS**

The on-board 8 position DIP switch banks (S1 & S2) and jumpers J4 are used to configure the basic operation modes of the TCO100.

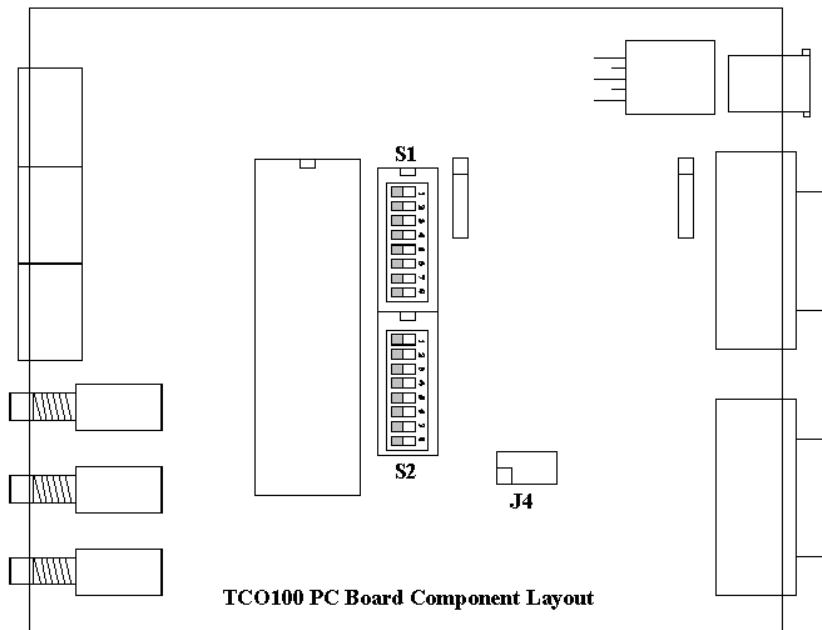

*Note: Some switch banks may refer to “on” as “closed” and “off” as “open”.*

**Time Zone/Daylight Savings Time Adjustments**

S1 switch positions 1 through 4 configure the hour offset the TCO100 will apply to generated time code. The offset is referenced to UTC (Greenwich Mean Time).

S1 Position	1	2	3	4	Hour offset
	off	off	off	off	No offset
	on	off	off	off	1 hour
	off	on	off	off	2 hours
	on	on	off	off	3 hours
	off	off	on	off	4 hours
	on	off	on	off	5 hours
	off	on	on	off	6 hours
	on	on	on	off	7 hours
	off	off	off	on	8 hours
	on	off	off	on	9 hours
	off	on	off	on	10 hours
	on	on	off	on	11 hours
	off	off	on	on	12 hours

S1 switch 6 in the *ON* position applies an additional ½ hour offset to the offset specified by switches 1 - 4.

S1 switch 5 in the *ON* position indicates that the offset specified by switches 1 - 4 & 6 is negative.

S1 switch 7 in the *ON* position instructs the TCO100 to apply a daylight savings time adjustment to generated time code (when applicable). *(Note: The default daylight savings time definition is U.S./Canada . The TCO100 with firmware version 2.4 or later uses the 2007 US/Canada DST standard., where daylight time begins on the second Sunday of March, at 2:00AM and ends on the first Sunday of November at 2:00AM. Additional daylight savings time configurations can be provided (permanently programmed) by MC on special order. )*

DST changeover for other areas of the world is available through RS-232 configuration.

S1 switch 8 in the *ON* position allows the time zone, daylight savings time, and other configuration parameters to be updated via RS-232 communication with the *CONTROL OUTPUT* port. See the section entitled RS-232 Interface for more information.

TIME CODE GENERATION

S2 switches 1 and 2 configure the time code output format of the TCO100.

S2 Position	1	2	Time code type
	off	off	SMPTE 30 frames/second (NDF)
	on	off	SMPTE 25 frames/second
	off	on	SMPTE 24 frames/second
	on	on	IRIG-B/B(1)

All other switches are reserved and should be left in the off (open) position.

TIME CODE ROUTING CONFIGURATION

*Important note: Pin Jumper J4 must be configured, in addition to the S2-1 and S2-2 switches, to configure/route generated time code to pin 6 of the DB-9. See figure 3 below.*

FIGURE 3

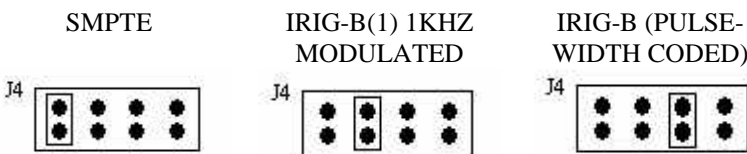

PHYSICAL CONNECTIONS/CONFIGURATION

### CONTROL INPUT WIRING DIAGRAM

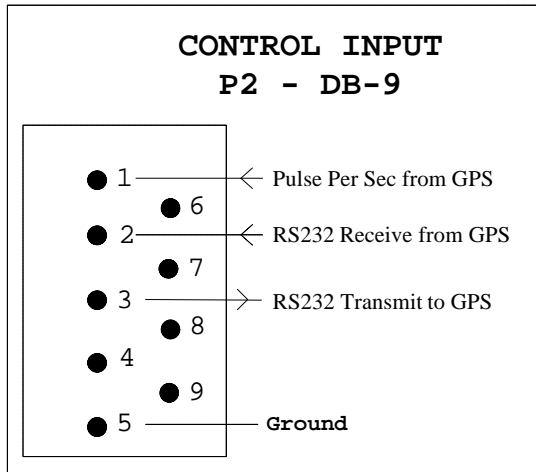

### CONTROL OUTPUT WIRING DIAGRAM

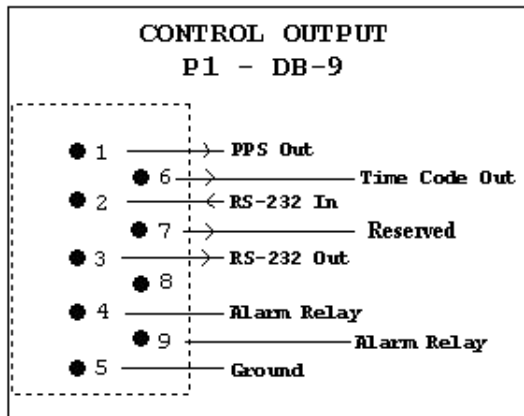

### CONTROL OUTPUT ADAPTER & CABLE

The TCO100 is supplied with a DB9 to BNC adapter (BNC9) that connects the time code output of the unit to a BNC connector. If the other signals are to be used then an appropriate cable can be fabricated locally by a competent technician or purchased separately from Masterclock. Check with the factory for price and availability.

### AVAILABLE OUTPUT SIGNALS

Pin 1 – PPS (pulse-per-second) signal synchronized to the 1Hz real-time reference of the time code generator. This PPS is available only when the TCO100 is generating time code.

Pin 2/3 – RS-232 interface to a host system. Pin 5 is the associated ground.

Pin 4/9 – Relay contact closure pins. This contact will close if the TCO100 is connected to a GPS200 and if the GPS200 loses sync with the GPS satellites.

Pin 5 – Associated ground for RS-232 and time code output.

Pin 6 – Time code signal output, as routed by the J4 jumper bank.

Pin 7 – Reserved

## TCO100 – GPS200 INTERCONNECT CABLE

The TCO100 can be synchronized to and disciplined by a Masterclock GPS200 master clock generator/receiver. A pin-to-pin (“straight-through”) cable with a DB-9 female connector at each end is required. Masterclock provides this part as part number TCO100CC. The cable is connected between to the *OUTPUT* connector on the GPS200 and the *CONTROL INPUT* connector on the TCO100.

Please visit the support FAQ (frequently asked questions) area of the Masterclock® website [www.masterclock.com](http://www.masterclock.com) to download or view GPS200 and TCO100 interconnect diagrams using the TCO100CC.

To discipline the TCO100 to the GPS200, the interconnect cable TCO100CC should be ordered with the system. This special cable provides suitable interconnect synchronization wiring and separate output wires terminated with a BNC connector for GPS200 time code output. This cable can also be purchased separately from Masterclock or fabricated locally by a competent technician. Check with the factory for price and availability. If fabricated on-site the cable should be as short as reasonably possible and should not exceed 3 ft – 1m in length.

## SIMPLIFIED GPS TO TCO WIRING DIAGRAM

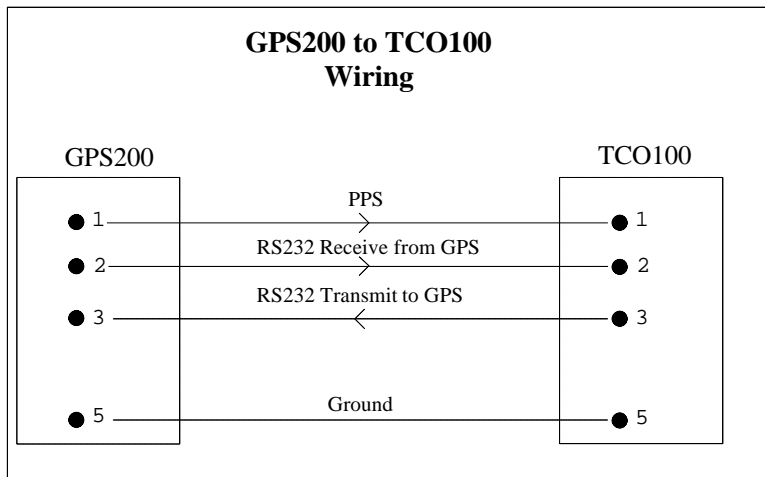

## RS-232 INTERFACE

The RS-232 serial interface on the *CONTROL OUTPUT* port of the TCO100 is a bi-directional communication port through which another application can monitor the operating parameters of the unit as well as provide advanced configuration parameters that are not available via the on-board dip switches. Specifications and instructions for programming the TCO100 via the RS-232 interface are beyond the scope of this manual. Please refer to the [TCO100 Serial Protocol Specifications](#) document, available for download from our web site <<http://www.masterclock.com>> or by contacting technical support.

## PROBLEMS - TROUBLESHOOTING

**Problem:** The unit appears to be generating time code but my decoding devices are not receiving anything and/or are functioning erratically.

### Resolutions:

Verify that S2 switches 1 & 2 are configured to generate the desired type of time code.

- 1) Verify that TCO100 jumper J4 is set to route the desired time code signal.
- 2) Verify all cabling and connectors by testing continuity. Check end-points with an oscilloscope, as necessary, to verify that the signal is present and at an appropriate level (about 1.8Vpp for SMPTE, or 5Vpp for IRIG-B).

**Problem:** The unit is generating time code but it is not the time of day/date that I expected.

Resolutions:

- 1) If the unit is or has not been connected to a synchronized GPS200 master clock then you may need to initialize the correct time and date using the front-panel buttons. Also verify that the time zone and daylight savings time configuration options switches are set correctly.

Problem: My TCO100 is connected to a GPS200 but does not appear to be synchronized to the master clock.

Resolutions:

- 1) The TCO100 will not synchronize to the GPS200 if the master clock has an invalid GPS fix. An invalid GPS fix is indicated by a solid or double-blinking green LED on the GPS200 front panel. Consult your GPS200 manual for more information.
- 2) Verify the cabling between the GPS200 and the TCO100.

Problem: When powering up the unit, time code generation always begins with 01:00:00 01/01/1998.

Resolution: There is a problem with the battery back-up for the real-time clock. Contact technical support.

**SPECIFICATIONS**

**TIME CODE OUTPUT**

Type:..... LTC (Longitudinal/Linear Time Code), forward running

Format:..... SMPTE - 24, 25 or 30 fps NDF (Non Drop-Frame)

Level: ..... Approx. - 2 Vpp

Connector: ..... DB-9 pin 6 (Single Ended, Unbalanced, pin 5 associated signal return/ground)

Format:..... IRIG-B(1) 1kHz, amplitude modulated

Level: ..... Approx. - 5 Vpp

Connector: ..... DB-9 pin 6 (Single Ended, Unbalanced, pin 5 associated signal return/ground)

Format:..... IRIG-B pulse-width coded

Level: ..... Approx. - 5 Vp

Connector: ..... DB-9 pin 6 (Single Ended, Unbalanced, pin 5 associated signal return/ground)

**TIMING CHARACTERISTICS**

Reference: UTC/GMT (default)

Date (SMPTE): Included in user bits per Leitch specification

Date (IRIG-B): Included in Control Functions (CF) per IEEE 1344 specification

Short term accuracy: < 10 μs (when locked to GPS)

Long term stability: same as GPS atomic clock in GPS satellites (when locked to GPS)

Drift (TXCO): +/- 1 min/year (standalone operation)

**PPS OUTPUT**

Pulse Per Second (PPS) ..... DB-9 pin 1 (pin 5 associated ground)

PPS is synchronized to the 1Hz on-time reference marker of the time code generator and is accurate to within < 10us of the aforementioned event. It is approximately 100ms wide and positive-going. Output circuit is a TTL open collector with internal pull-up resistor.

**ALARM OUTPUT**

The alarm relay contacts are connected to pins 4 & 9 of the DB-9 Control Output connector and will be closed when the unit is not synchronized to a GPS200 with a satellite fix. The contacts are normally open and are for low power signaling with ratings not to exceed 28V & 200 ma.

**FRONT PANEL INDICATORS (LEDS)**

6 each, 7 segment LED displays time or date

**REMOTE INTERFACE**

RS-232C DTE configuration: control of instrument functions and parameters. Factory defaults: baud rate 9600, 8 data bits, 1 start bit, 1 stop bit, no parity.

**PHYSICAL**

Size: ..... 1.5 x 4.1 x 5.5 in. (3.8 x 10.4 x 14 cm)

Weight ..... 17 oz. (480 g)

**ENVIRONMENTAL**

The TCO100 is not water or moisture proof. Treat it as you would any other delicate electronic device and do not expose it to water, moisture, excessive heat or physical abuse.

Temperature (operating) ..... 0 to +40 °C

Temperature (storage)..... - 40°C to + 80°C

Humidity ..... Up to 90% Non-Condensing @ +25 °C

**POWER SUPPLY REQUIREMENTS**

Input Voltage .....12 – 28 VDC

Input Power Connector .....2 mm male power jack, Center Pin +

Power Consumption @12V .....220 ma (2.64W)

**BATTERY OPERATION**

If desired the unit can be operated from an external DC power source (12- 28 VDC range). Observe voltage polarity - printed on the rear panel.

**NOTES**

**NOTE 1**

The temperature must remain within a 10° C range between 10 and 40° C. The typical specifications that are given apply when installed in a regulated temperature environment (typical office/lab) and allowed to operate and stabilize for several days without power interruption.

**NOTE 2**

When a quartz oscillator has not been operated for a period of time, or if it has been subjected to severe thermal or mechanical shock as might be encountered during product shipment, the oscillator may take some time to stabilize. In most cases, the oscillator will drift and then stabilize at or below its specified rate within a few days after being turned on. In isolated cases, depending upon the amount of time the oscillator has been off and the environmental conditions it has experienced, the oscillator may take up to one week to reach its specified aging rate and to operate without significant frequency 'Jumps'.

When a TCO100 is initially turned on and locked to the GPS200, it has a 95% probability of meeting unlocked (holdover) specifications after 48 hours of GPS synchronized operation. The longer the GPS receiver (and its quartz oscillator) operates, the better its stability and unlocked (holdover) performance becomes.

**OPTIONS & RELATED HARDWARE**

Rack Mount



Time Code Generator GPS200A



TCO100CC – TCO100 to GPS200A Interconnect Cable

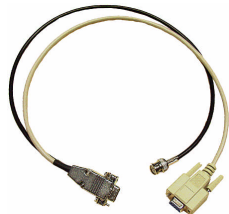

Time Code Switcher



TCR100 - Time Code Reader Card

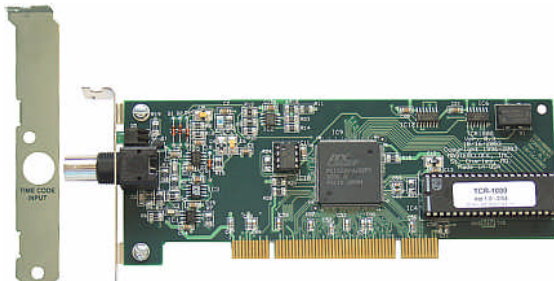

TCR-500 - Time Code Reader Card

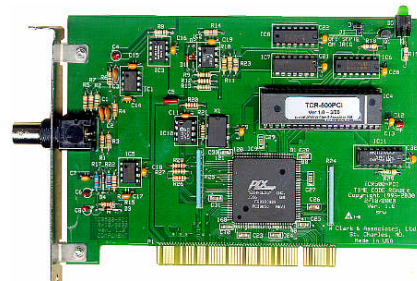

TCD200 Time Code Driven Clock



TCD26 Time Code Driven Clock



## **LIMITED WARRANTY**

This Masterclock (hereinafter MC) product warranty extends to the original purchaser.

MC warrants the TCO100 against defects in materials and workmanship for a period of one year from date of sale. If MC receives notice of such defects during the warranty period, MC will, at its option, either repair or replace products which prove to be defective.

Should MC be unable to repair or replace the product within a reasonable amount of time, the customer's alternate remedy shall be a refund of the purchase price upon return of the product to MC. This warranty gives the customer specific legal rights. Other rights, which vary from state to state or province to province, may be available.

### Exclusions

The above warranty shall not apply to defects resulting from improper or inadequate maintenance by the customer, customer-supplied software or interfacing, unauthorized modification or misuse, operation outside of the environmental specifications for the product or improper site preparation and maintenance (if applicable).

### Warranty Limitations

MC MAKES NO OTHER WARRANTY, EITHER EXPRESSED OR IMPLIED, WITH RESPECT TO THIS PRODUCT. MC SPECIFICALLY DISCLAIMS THE IMPLIED WARRANTIES OF MERCHANTABILITY OR FITNESS FOR A PARTICULAR PURPOSE.

In any state or province which does not allow the foregoing disclaimer, any implied warranty of merchantability or fitness for a particular purpose imposed by law in those states or provinces is limited to the one-year duration of the written warranty.

### Exclusive Remedies

*THE REMEDIES PROVIDED HEREIN ARE THE CUSTOMER'S SOLE AND EXCLUSIVE REMEDIES. IN NO EVENT SHALL MC BE LIABLE FOR ANY DIRECT, INDIRECT, SPECIAL, INCIDENTAL, OR CONSEQUENTIAL DAMAGES, WHETHER BASED ON CONTRACT, TORT, OR ANY OTHER LEGAL THEORY.*

In any state or province which does not allow the foregoing exclusion or limitation of incidental or consequential damages, the customer may have other remedies.

## **HARDWARE SERVICE**

You may return your TCO100 to MC for repair either under warrant or on a time & material basis. Please contact the factory or see our web site for a return merchandise authorization (RMA) before returning the unit. When you return your TCO100 for service, you must prepay all shipping charges, duty, and taxes. For international returns please contact the factory.