

BRITISH AMERICAN SATELLITE TIME TRANSFER EXPERIMENT

Roger Easton

Naval Research Laboratory

At last year's PTTI we ran an actual time transfer between two buildings approximately 300 feet apart. We did this by means of a satellite approximately 500 miles away. Figure 1 shows the results obtained.

This year the Naval Observatory asked that we perform a similar experiment with the Royal Greenwich Observatory (RGO). The Royal Greenwich Observatory, with headquarters in a fifteenth century castle, is at the site shown on the map (Figure 2).

The final data, which we will describe more fully, is shown in Figure 3. The two sets of data are displaced 15.2 microseconds. This displacement represents the difference between the Naval Observatory and RGO clocks as measured in this experiment.

Last year we showed a bit about the theory of time transfer. However, since there is always someone in the audience who is new and did not get the word, I will repeat myself briefly.

REVIEW

The satellite has four advantages for navigation and time transfer: (1) well-known position; (2) line-of-sight signal, which allows the use of UHF; (3) worldwide coverage; and (4) a celestial navigation solution identical to the one used in celestial navigation for 200 years (see Figure 4). The diagram indicates the observer on a ship and his method of measuring the range to the satellite. He knows the radius of the earth and the distance from the center of the earth to the satellite. Triangulation gives him the angle θ , the same angle a celestial navigator would have used to observe a star in the same geographical position of the satellite.

Figure 5 is a diagram of range measurement by phase measure. The satellite has a clock (in this case, a 100-kHz clock) that is counted down: 100, 10, 1, 0.1 kHz. The observer has a similar clock. The observer receives the signal from the satellite and compares the phase of the 100-kHz received signal to his own 100-kHz to get a phase reading; he repeats this step for the other frequencies. If the satellite clock is synchronized to the observer clock, this phase reading gives a measurement of the time delay between the satellite and the observer.

Figure 6 is a schematic of the actual procedure measured in 6800, 920, 18, and 8.6, 10 microseconds; with 100-cycle, 1000, and 10,000 microseconds countdown. The satellite clocks and the navigator clocks are synchronized in this case. However, by the time this signal gets from the satellite to the navigator, his clock has changed because it took 6800 microseconds for the signal to arrive. The phase comparison for the first clock is 0.68 of a cycle, which gives a rough reading of 6800 microseconds. For the second clock, the reading

is 0.92, so it should read 6920 microseconds. For the third clock the reading is 0.18, so it should read 6918 microseconds; and for the fourth clock it is 8.6, so it should read 6918.6 microseconds.

Figure 7 is an intercept chart invented a hundred years ago by St. Hilaire, a French naval officer. The precomputed chart shows the assumed position, the direction of the satellite at 16 minutes past the hour, and the computed time delays from the satellite at 16 minutes past the hour (10,870 microseconds). Thus, one can plot the predicted satellite positions for these times, compute the distance from the satellite to the assumed position, and convert this to time delay.

Figure 8 shows a fix determined on the intercept chart. At 16 minutes past the hour the time delay is read, a right angle is drawn, and a line of position (LOP) is established. Other LOPs are drawn in a similar fashion. If there are no errors, the fix is perfect. But more often than not, the result will be similar to that pictured in Figure 9, an intercept chart showing the effect of synchronization error on plot, which is identical to having an instrument error for a celestial fix. The navigator is at the center of the arc of the circle; and the radius is the time error between his clock and the satellite clock. Thus the use of this technique allows both navigation and time transfer.

Figure 10 is a photograph of the satellite in current use, Timation II. It was launched over two years ago on the aft rack of an Agena rocket. Table 1 lists the characteristics of Timation I (which failed after two years because of the failure of the gravity-gradient boom), Timation II, and Timation III (scheduled for launch in December 1972).

Table 1
Timation Satellite Characteristics.

	I	II	III
Launch Date	31 May 1967	30 Sept 1969	Proposed
Altitude	500 n.mi.	500 n.mi.	7500 n.mi.
Inclination	70°	70°	135°
Weight	85 lb	125 lb	425 lb
DC Power	6 W	18 W	90 W
Frequencies	400 MHz	150 and 400 MHz	400, 1600 MHz
Max Mod Freq	100 kHz	1 MHz	8 MHz
Osc Stab	3pp10 ¹¹	.5-1pp10 ¹¹	1-2pp10 ¹²

Figure 11 shows the aging rates of the oscillators on Timation I and II. When the crystal oscillator on Timation II (which is tunable from the ground) was launched into space, it had a positive aging rate, 2 parts in 10^{11} per day. This rapidly decreased to more than minus 4 parts in 10^{11} , but has now come back up to minus 2 parts in 10^{11} per day. This would not be expected from any ground measurements. The rate of Timation I started at a much lower rate and gradually became more negative. The difference was caused by proton bombardment on the crystal. The reason for the different shapes of the curves is that Timation I had a much higher positive coefficient when it was launched and the proton bombardment (largely proton, some electron) compensated for it almost directly, thus the almost zero aging rate. Timation II had a much lower aging rate and the protons overcompensated for it, which caused the highly negative aging rate for part of the time. It was determined that the rate was largely caused by protons because Timation II had a lead shield that shielded out the electrons, and it still had almost the same rate that would have been expected without the lead shield.

THE RGO-NAVOBS EXPERIMENT

For the RGO experiment we used the same RCA receiver we showed last year. This receiver used the 10/1 frequency step in the satellite transmitter, thus resolving the ambiguity between tones to give a final answer on range delay. However, although this receiver resolves the ambiguity, it does not always do so correctly, as will be shown.

While we were making these measurements in England, other people were making similar ones here in Washington on other (and less ambiguous) equipment. Points were read once per minute at each site. However, England is far enough from Washington that no points were run concurrently. Figure 12 shows the data links used in the computations.

Figure 13 shows the relationship of the data for three near-consecutive passes as corrected postdiction for satellite position, satellite frequency, and satellite clock phase.

Figures 14 and 15 show expanded data for two of the passes shown on Figure 13. It is seen that the equipment used at RGO does contain some ambiguity. These ambiguous points caused some problems but were corrected by using the large number of good data points available.

Each pass was smoothed at the point of nearest approach to provide a single point in Figure 16. The results we obtained agree within 1.5 microseconds with LORAN C measurements made at RGO. A traveling clock check made before the experiment indicated a discrepancy of approximately 1.5 microseconds when compared to LORAN C. The next clock comparison is scheduled for later this year. So, while the absolute accuracy of the time-transfer technique used is not known, it appears that accuracies of one-half microsecond are readily available.

ACKNOWLEDGEMENTS

This experiment required a large effort by many people, including Donald W. Lynch, James Buisson, Thomas McCaskill, Cecelia Burke, and Hugh Gardner of NRL, and Humphry Smith, Henry Gill, Ann Strong, and Antony Seebrook of RGO. In addition the orbits were computed with the aid of NRL and TRANET people around the world.

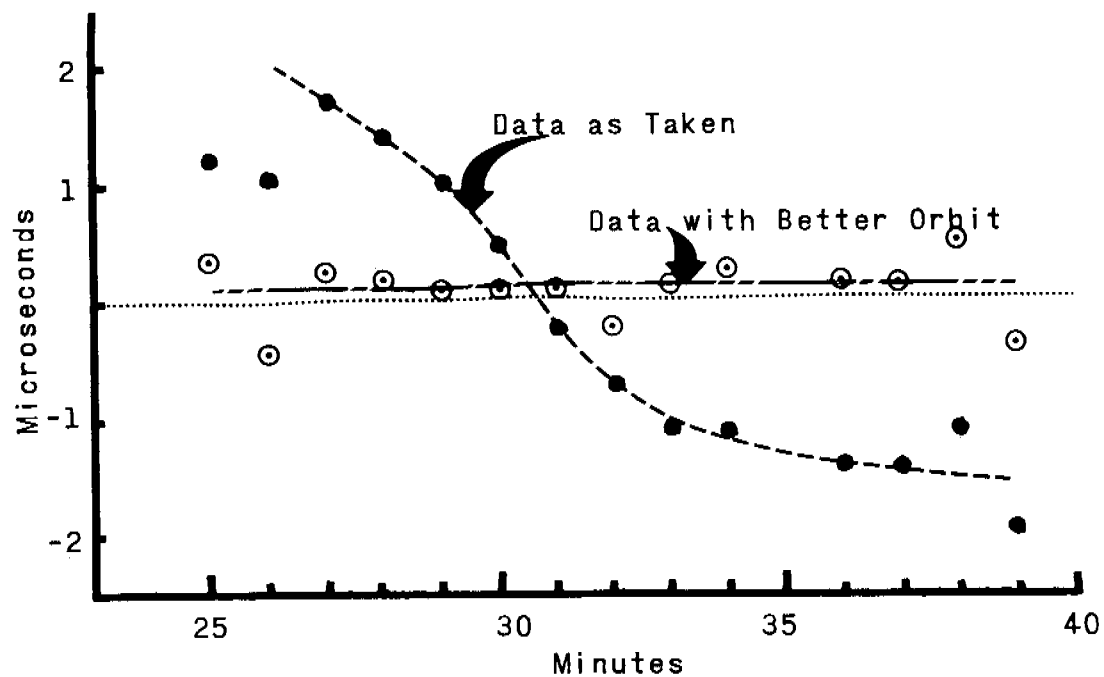

Figure 1

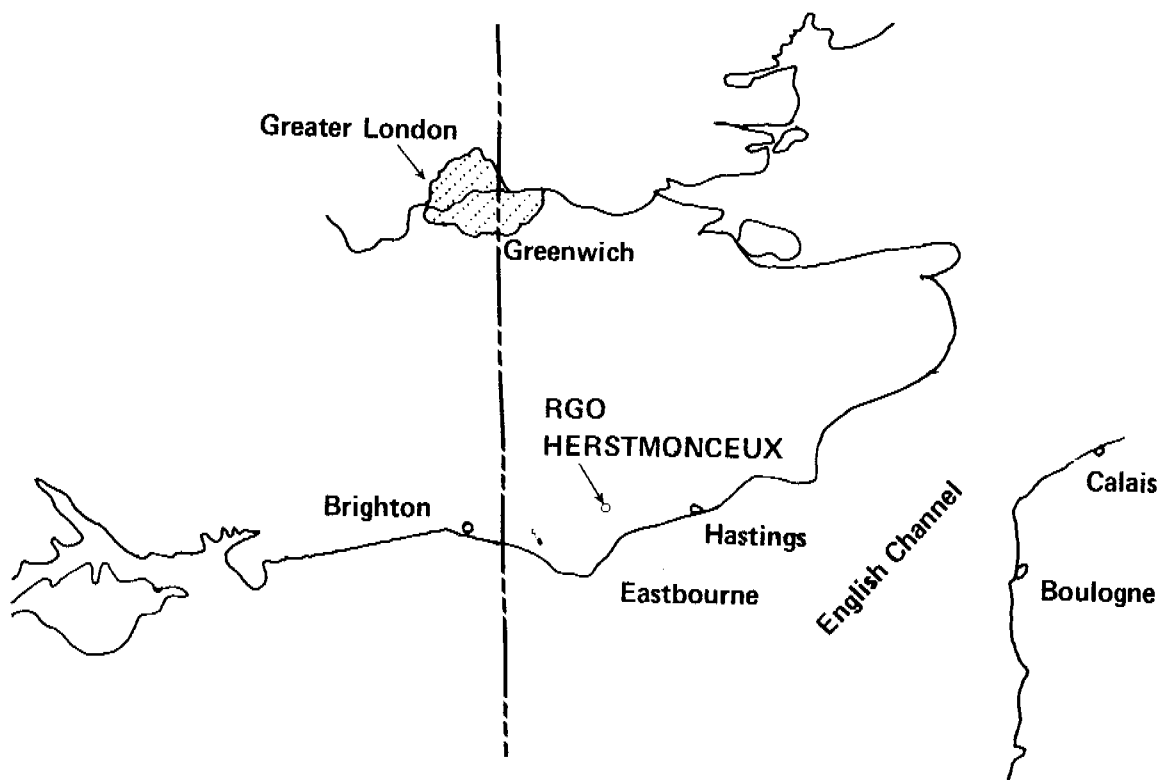

Figure 2. Location of the Royal Greenwich Observatory.

TIME TRANSFER - TIMATION II SATELLITE
 NAVAL RESEARCH LABORATORY AND ROYAL GREENWICH OBS.

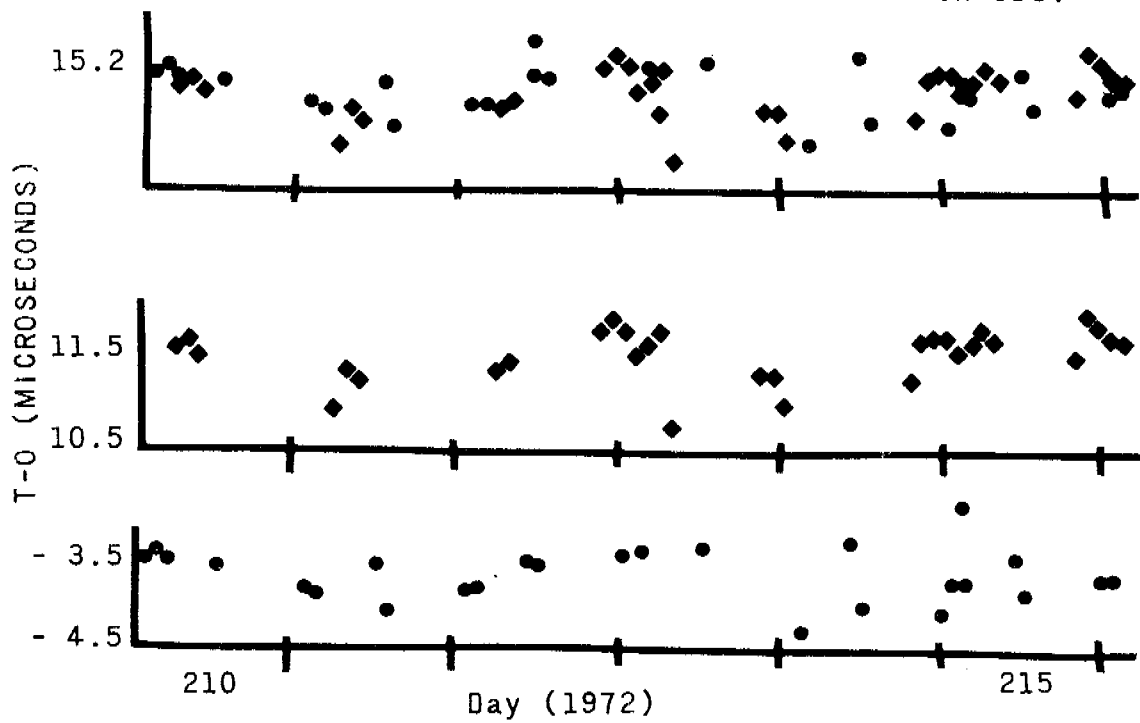

Figure 3. Timation II time-transfer experiment results.

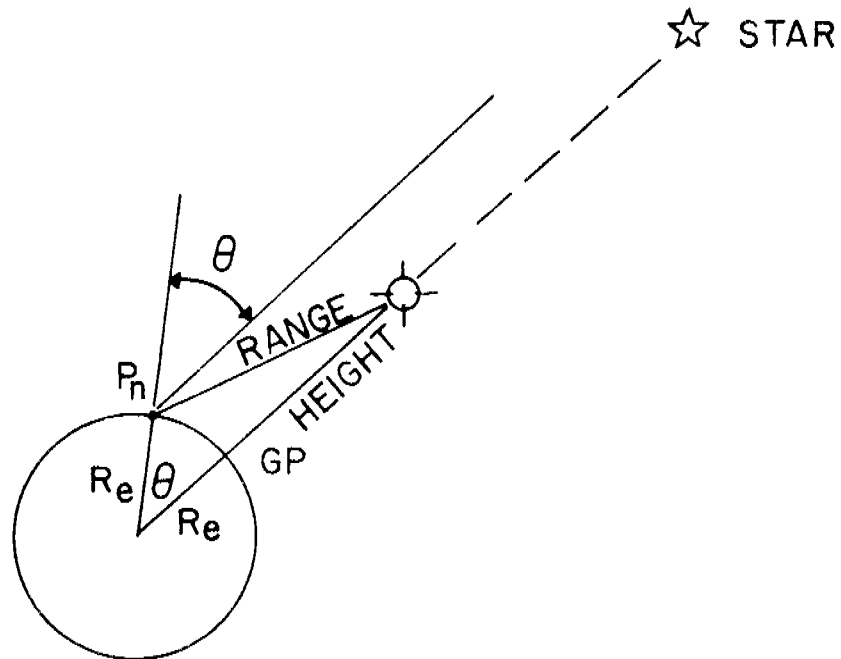

Figure 4. Transform to celestial navigation.

OBSERVER CLOCK

SATELLITE CLOCK

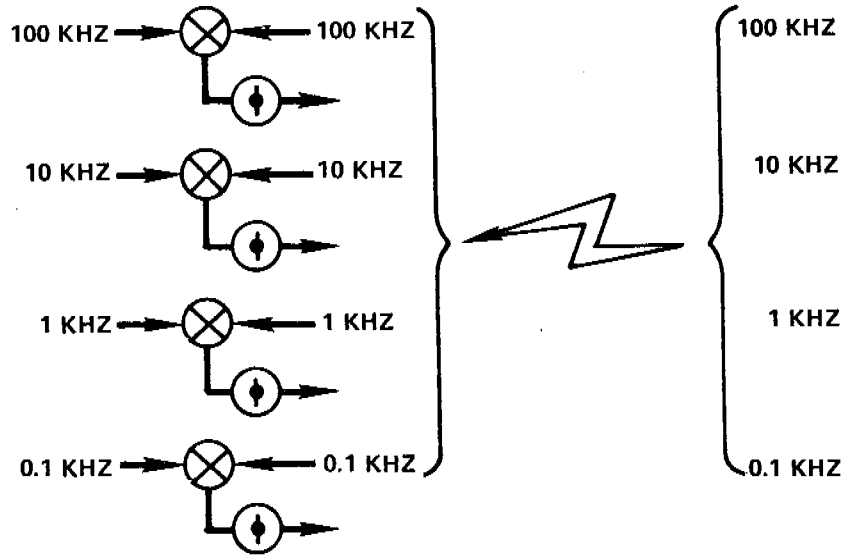

Figure 5. Range measurement by phase measurement.

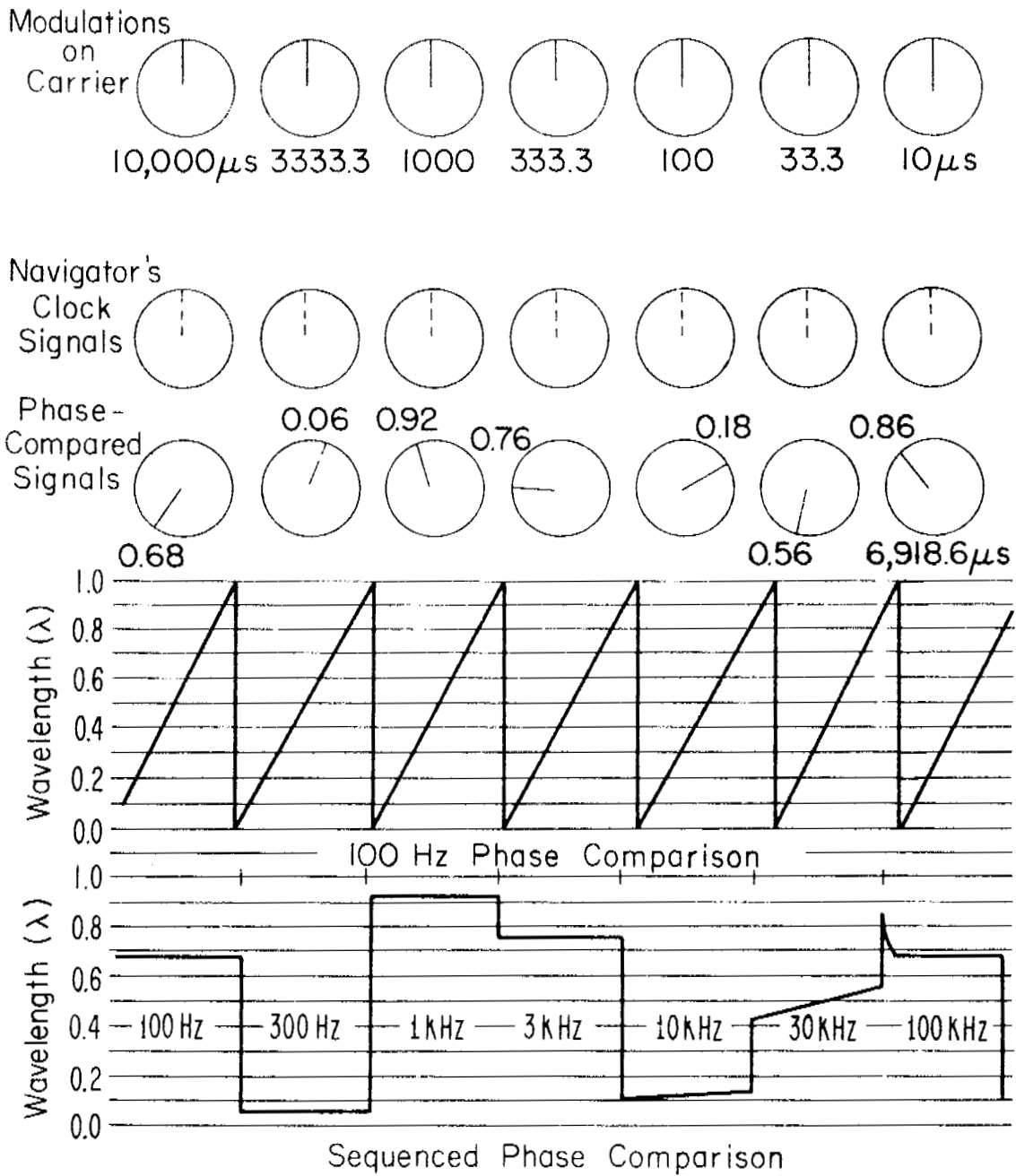

Figure 6. Schematic procedure.

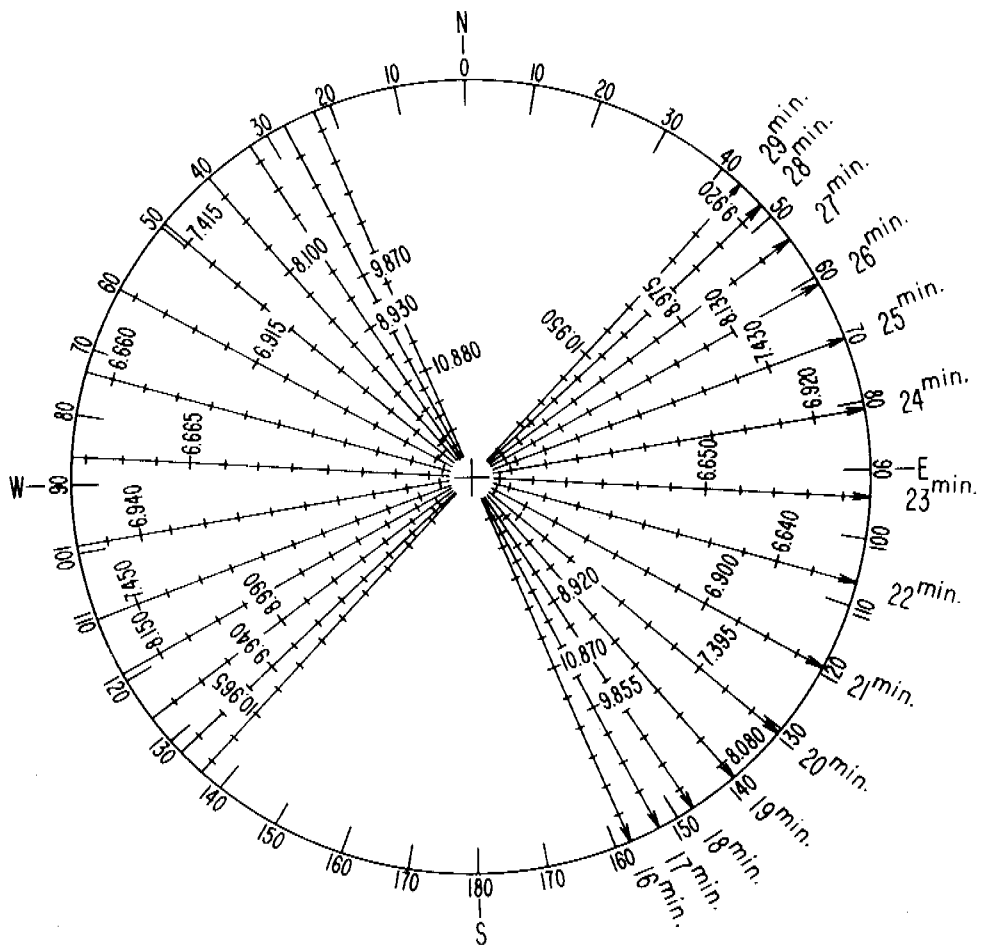

Figure 7. Precomputed intercept chart.

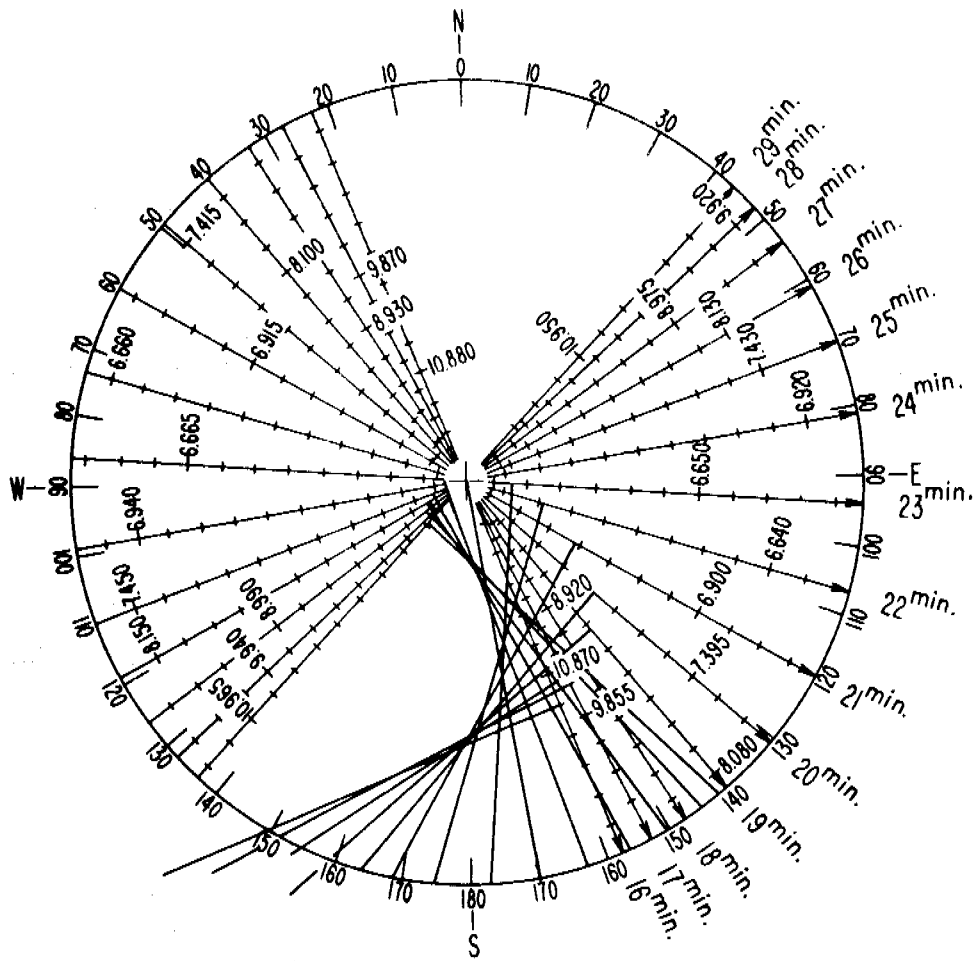

Figure 9. Intercept chart showing effect of synchronization error on plot.

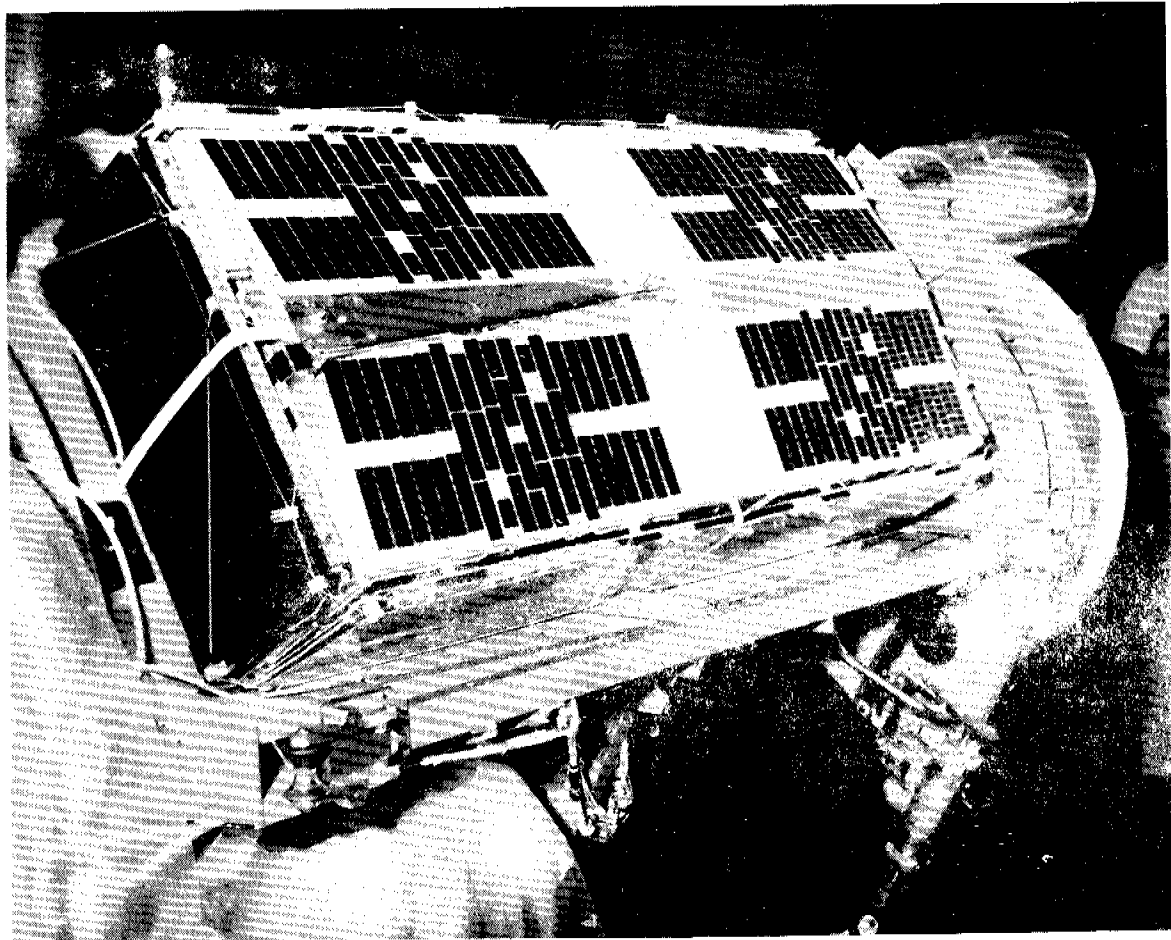

Figure 10. Timation II.

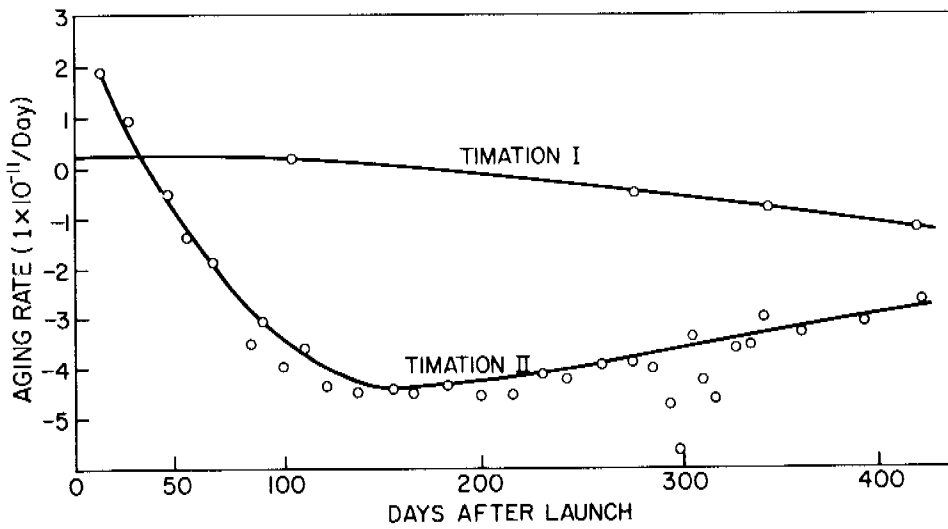

Figure 11. Aging rates of crystal oscillators.

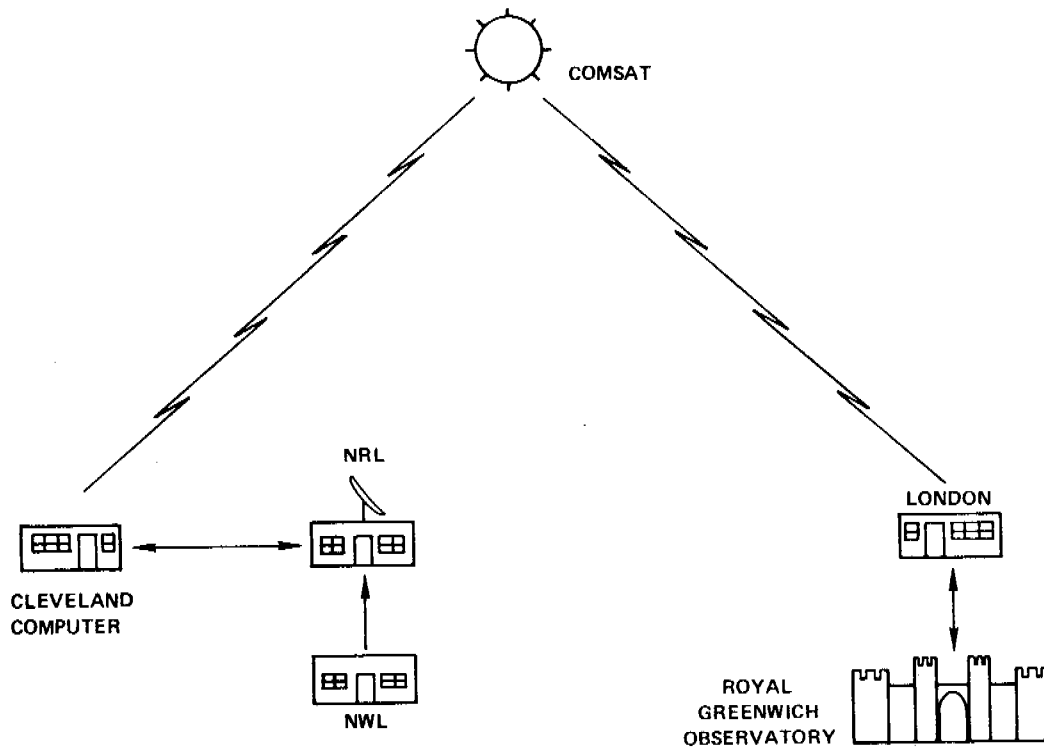

Figure 12. Data links for the NRL-RGO time-transfer experiments.

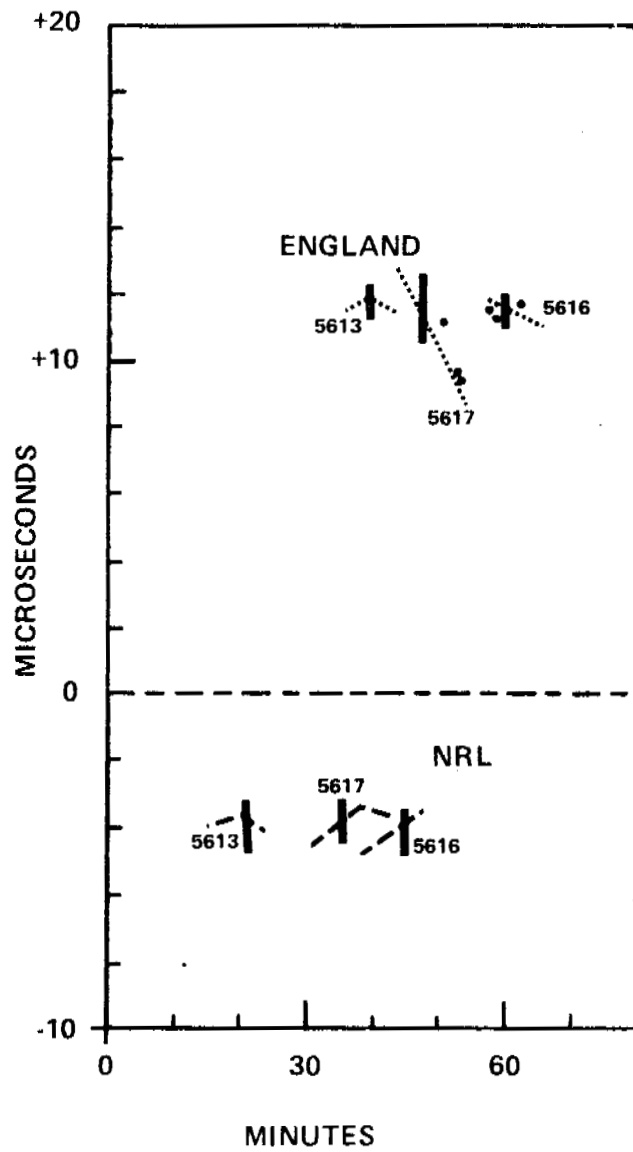

Figure 13. Relationship of data for three near-consecutive passes.

TIME COMPARISON

NAVAL RESEARCH LABORATORY, USA - TIMATION II

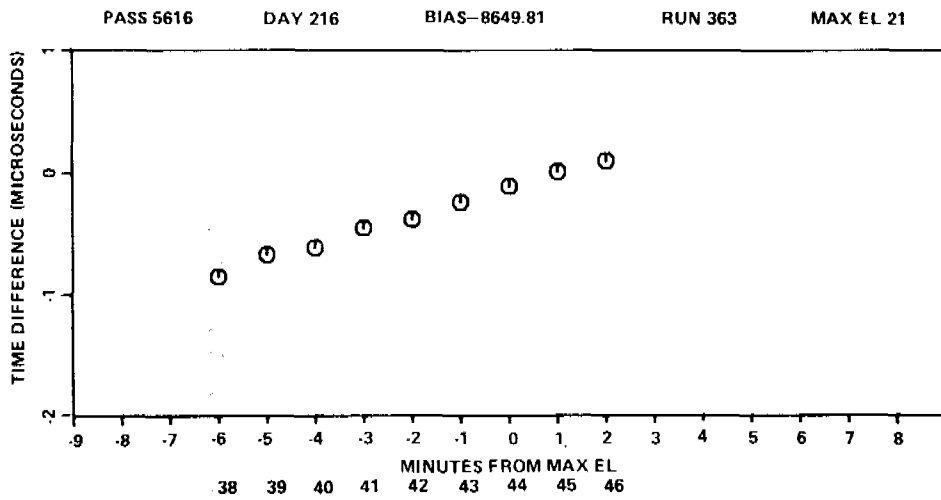

Figure 14. Expanded data from Figure 13.

TIME COMPARISON

ROYAL GREENWICH OBS., ENG. - TIMATION II

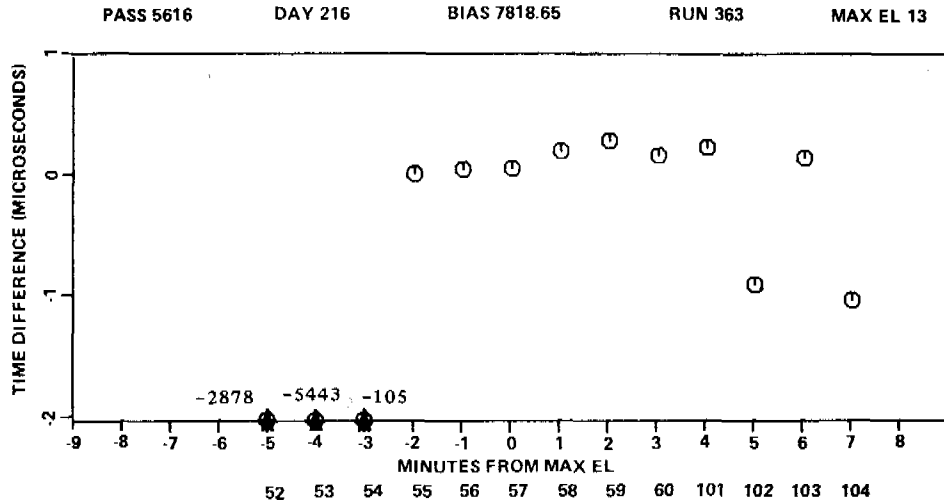

Figure 15. Expanded data from Figure 13.