

PRECISE TIMING CORRELATION IN TELEMETRY RECORDING AND PROCESSING SYSTEMS

R. B. Pickett

F. L. Matthews

ITT Federal Electric Corporation
Vandenberg Air Force Base

ABSTRACT

Independent PCM telemetry data signals received from missiles must be correlated to within ± 100 microseconds for comparison with radar data. Tests have been conducted at the Space and Missile Test Center (SAMTEC), Vandenberg Air Force Base, California, to determine RF antenna receiving system delays; delays associated with wideband analog tape recorders used in the recording, dubbing and reproducible processes; and uncertainties associated with computer processed time tag data. Several methods used in the recording of timing are evaluated. Timing error versus tape recorder head alignment is plotted. Tape recorder phase lead effects on time code formats and data are given. The time bias associated with computers processing of data is presented. Sources of timing errors and the calibration and operating techniques available to minimize these errors are discussed. Through the application of a special time tagging technique, the cumulative timing bias from all sources is determined and the bias removed from final data. Conclusions from test data show that relative time differences in receiving, recording, playback and processing of two telemetry links can be accomplished with a ± 4 microseconds accuracy. In addition, the absolute time tag error (with respect to UTC) can be reduced to less than $15 \mu \text{sec}$. This investigation is believed to be the first attempt to identify the individual error contributions within the telemetry system and to describe the methods of error reduction and correction.

INTRODUCTION

Missiles launched from Vandenberg Air Force Base in California are tracked by systems located throughout the world. Radars provide position and velocity data in terms of range, azimuth, elevation and range rate. Telemetry stations receive information encoded and transmitted from the missile. For missiles configured with inertial guidance systems, position and velocity information in terms of X, Y, Z and \dot{X} , \dot{Y} , \dot{Z} is transmitted on the telemetry link.

The continued improvement in ballistic missile performance places an ever increasing accuracy requirement on position and velocity data. When sensor

performance capabilities do not meet the accuracy requirements directly, analysts use multistation solutions to refine the trajectory data. Such solutions may include inputs from widely spaced radars as well as the inertial guidance data. When merging the sources, timing offsets are particularly troublesome, as such errors propagate in a complex manner during the merging.

In order to avoid these problems, timing offsets are limited to ± 100 microseconds (μs) or less. This reduces the position error due to timing alone to less than 2.4 feet, even at escape velocity. In practical terms, this means that data received at stations throughout the world must be synchronized to within $\pm 100 \mu s$ of UTC.

Range Timing System

The SAMTEC timing system accuracy is directly traceable to the U. S. Naval Observatory's Coordinated Universal Time (UTC). This traceability is maintained as shown in Figure 1 through the SAMTEC Precision Measurement Laboratories (PML) Precise Time Reference Station (PTRS). The PML maintains a calibration accuracy of $\pm 2.0 \mu s$ of epoch USNO-UTC master clock. The PML has the responsibility to maintain the four SAMTEC Central Time Signal Generators (CTSG) Cesium Beam primary frequency and clock standards in calibration and synchronization with UTC (USNO). The CTSG systems are installed at Vandenberg Air Force Base and Pillar Point Air Force Station, California; Kaena Point, Oahu Island, Hawaii; and Canton Island, Phoenix Island Group. Each CTSG is equipped with dual cesium standards, frequency dividers and clocks, alarm and transfer circuitry, Inter-Range Instrumentation Group (IRIG) Time Code Generators and distribution amplifiers. At specified calibration periods, the PML transports a portable cesium "flying clock" to each CTSG to calibrate and synchronize the CTSG cesiums with UTC (USNO). Any drift in the "flying clock" is accounted for in the PML.

As shown in Figure 2, the distribution of the IRIG time code formats A, B, D, E and H and 1, 10, 100 pps and 1, 10 and 100 kpps pulses is generally accomplished over telephone plant cable pairs or a UHF radio system. The timing circuits provide radar, telemetry and other instrumentation systems with standard time code formats. Total delays at each site are then determined with a portable frequency standards and a computing counter, as shown in Figure 3.

Radar Synchronization

As shown in Figure 4, the master timing pulse at each radar station is routed from the timing center to the radar area and then to radar equipment where interrogate pulses are initiated. It is these 20 pps pulses which actually "freeze"

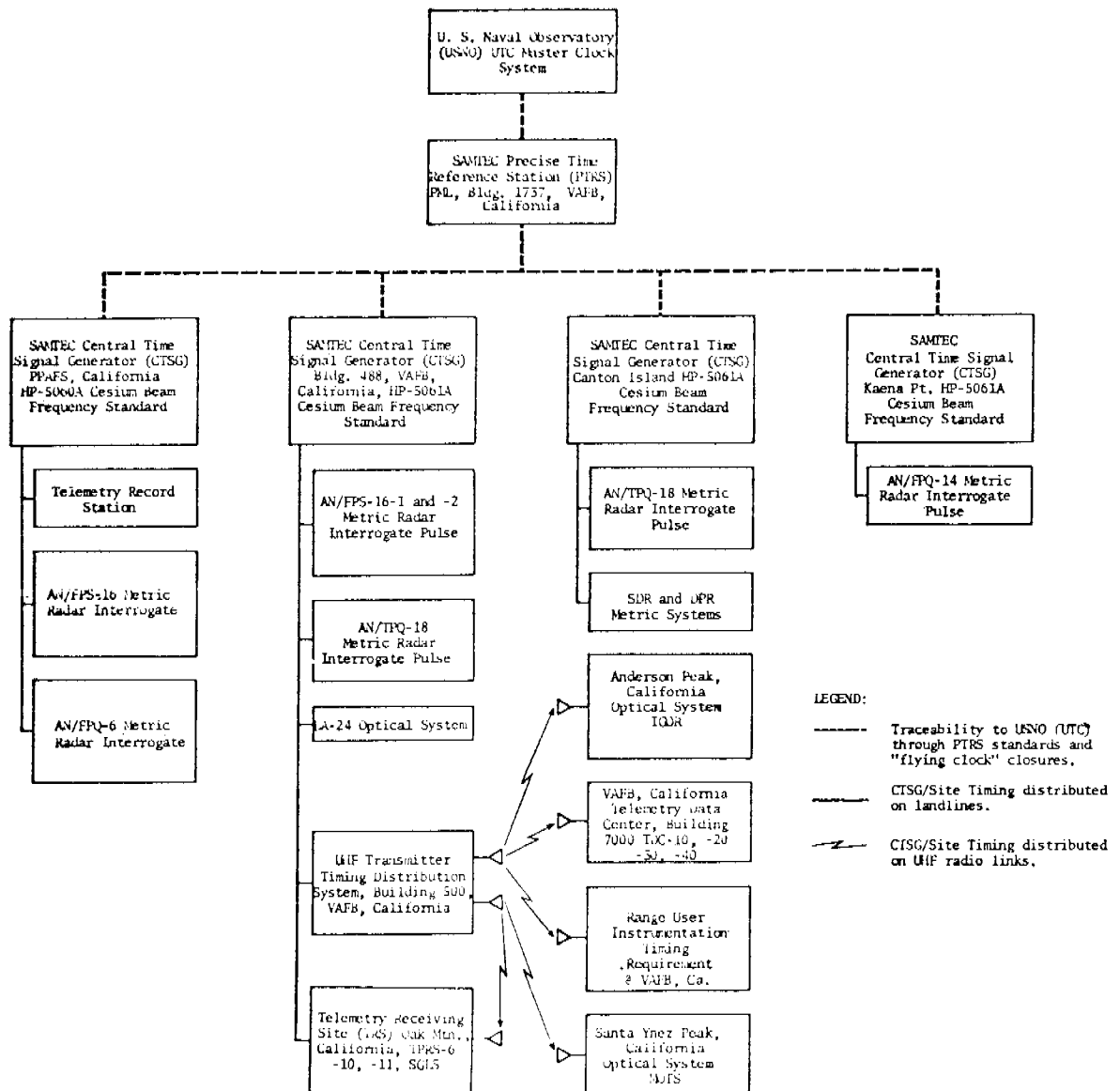

Figure 1. SAMTEC Instrumentation Systems UTC/IRIG Timing and Frequency Accuracy Traceability to USNO

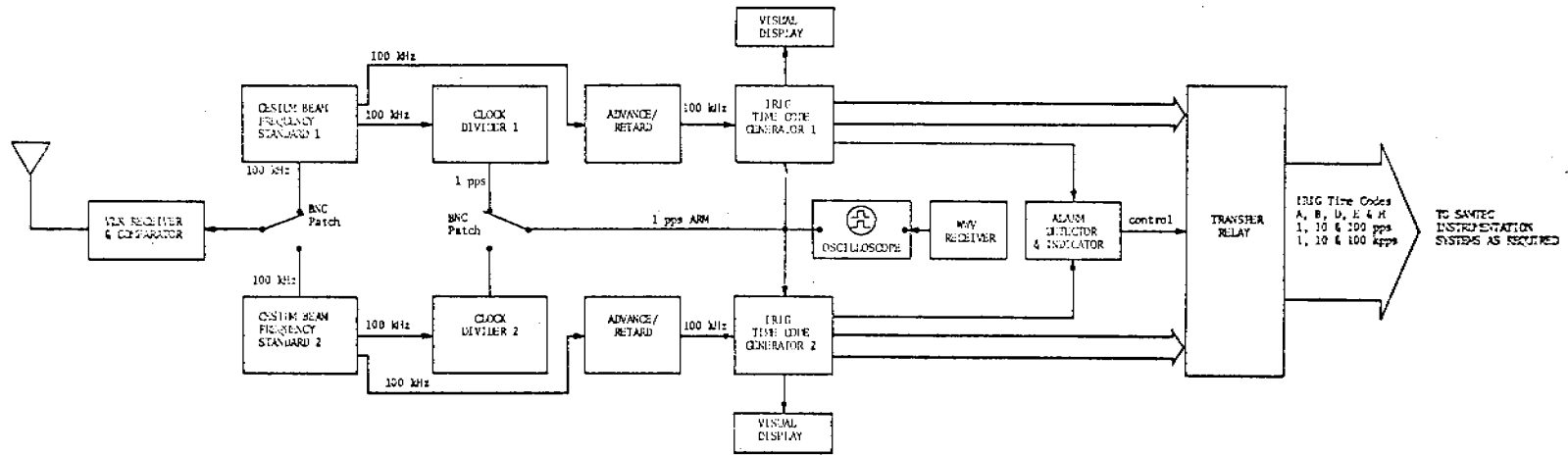

Figure 2. Typical Central Time Signal Generator

III

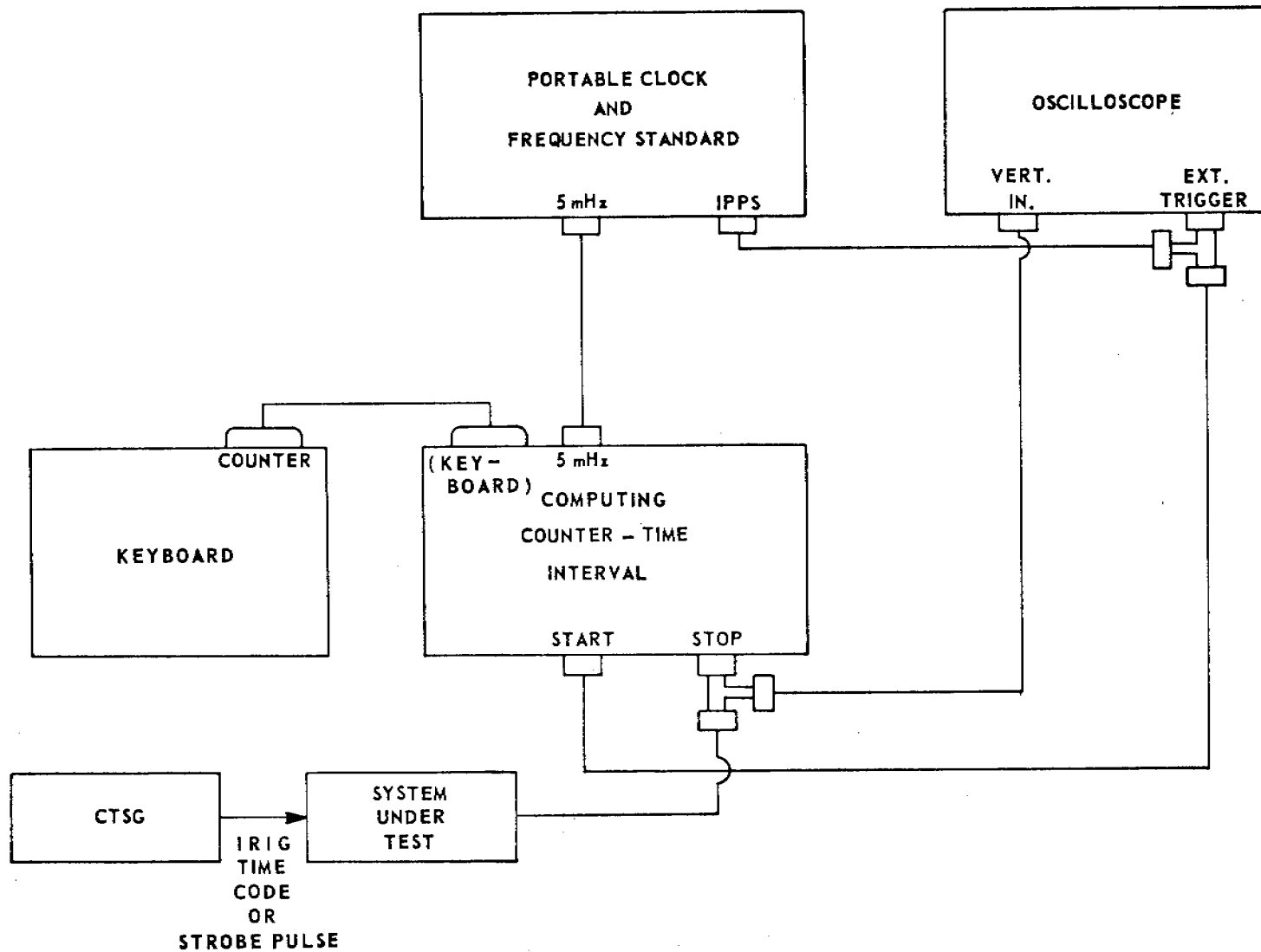

Figure 3. Typical Instrumentation Timing Accuracy Test Equipment Configuration

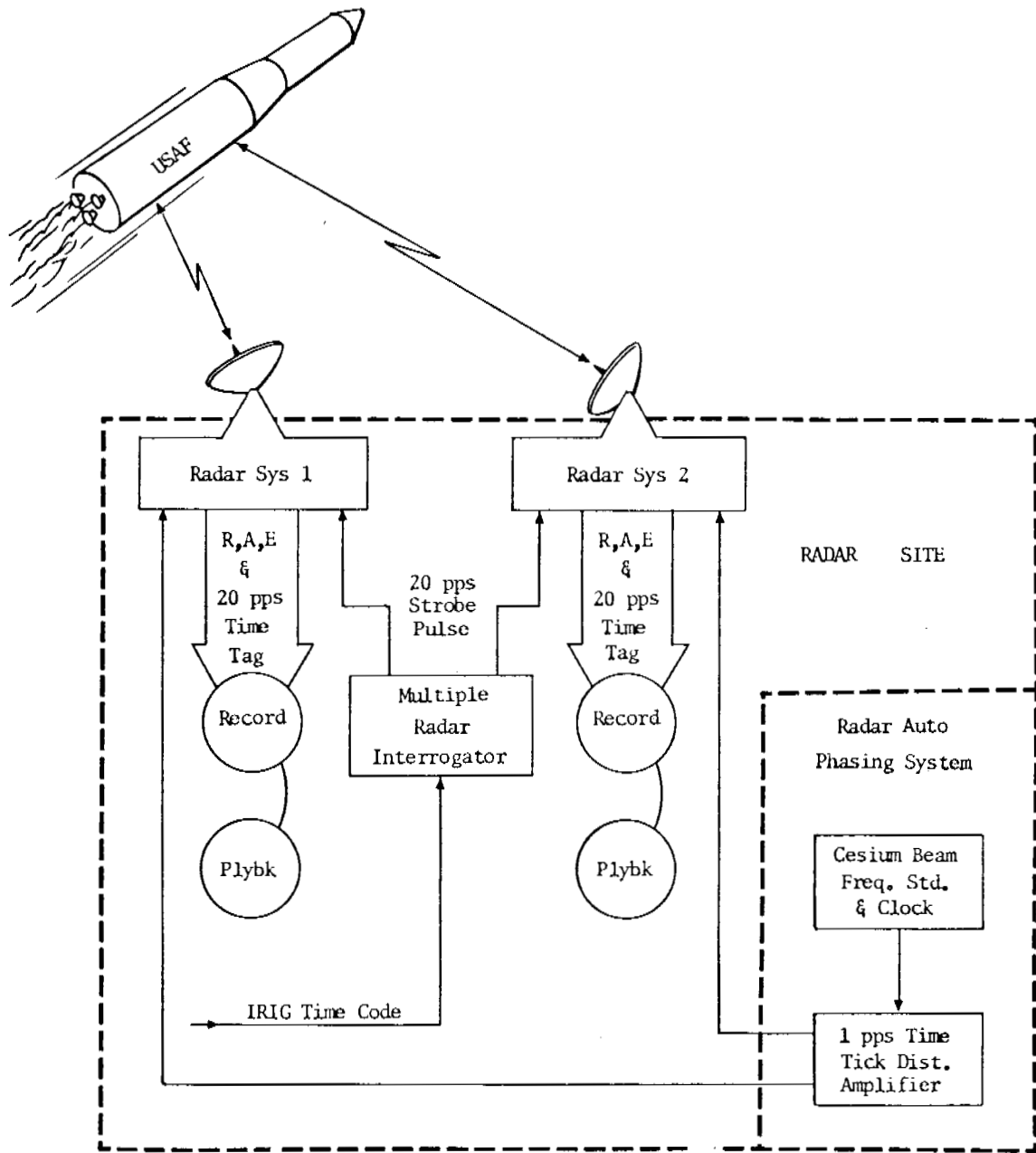

Figure 4. Multiple Radar Interrogator Time Tag Data Synchronization

the data registers. The data is then "dumped" and stored on tape, along with timing. The delay of the strobe pulse in relation to UTC is directly measured quarterly. This delay is added to the computed drift of the master clock to obtain an estimate of the total offset on each operation.

As an additional precaution, a backup cesium standard is located at the radar site. The 20 pps pulses are compared with the cesium 1 pps "on time" pulse prior to each operation. If the difference in time between the pulses is not within $\pm 25 \mu\text{s}$ of the designated delay for the site, the actual difference must be logged by the operator. Thus quarterly measurements plus pre-operational checks assure that all radar data can be accurately aligned for merging.

Telemetry Synchronization

As shown in Figure 5, telemetry stations synchronize a time code generator to the incoming IRIG signal. The generator then outputs "clean" IRIG timing which is recorded on magnetic tape. Also, data from the receiving system is recorded on adjacent tracks of the same tape. During post flight processing, the magnetic tape is replayed, data and timing signals are shaped, and both are inputted for computer processing. Part of the processing requirement is to correlate range timing to the time of data reception at the station to within one computer word time. (Typically $178 \mu\text{s}$ on critical programs). Unfortunately, errors in the recording/reproducing system may accumulate to several hundred microseconds and must be corrected on the final data product. The significant contributions to the accumulated error have been measured, and are discussed below.

- a. Figure 5 shows the mean RF receiving system and recorder time delays from three antenna systems for both predetection and post-detection recording.
- b. Several models of tape recorders were tested. Figure 6 illustrates that each type of recorder reacts differently to the IRIG A 10kHz and IRIG B 1kHz carriers. It was found as shown in Figure 7, that a dubbed tape had approximately doubled the time delay of the original tape.
- c. Head azimuth alignment causes only $1 \mu\text{s}$ of timing error, as shown in Figure 8, if heads are aligned within IRIG specifications.
- d. As shown in Figure 9, an error of up to $33 \mu\text{s}$ may result from allowable even and odd head placement tolerances.
- e. During playback, the time code generator decodes the IRIG timing signal and outputs timing pulses for computer use. As shown in Figure 10, it was found that jitter on the pulses was significant for IRIG B codes.

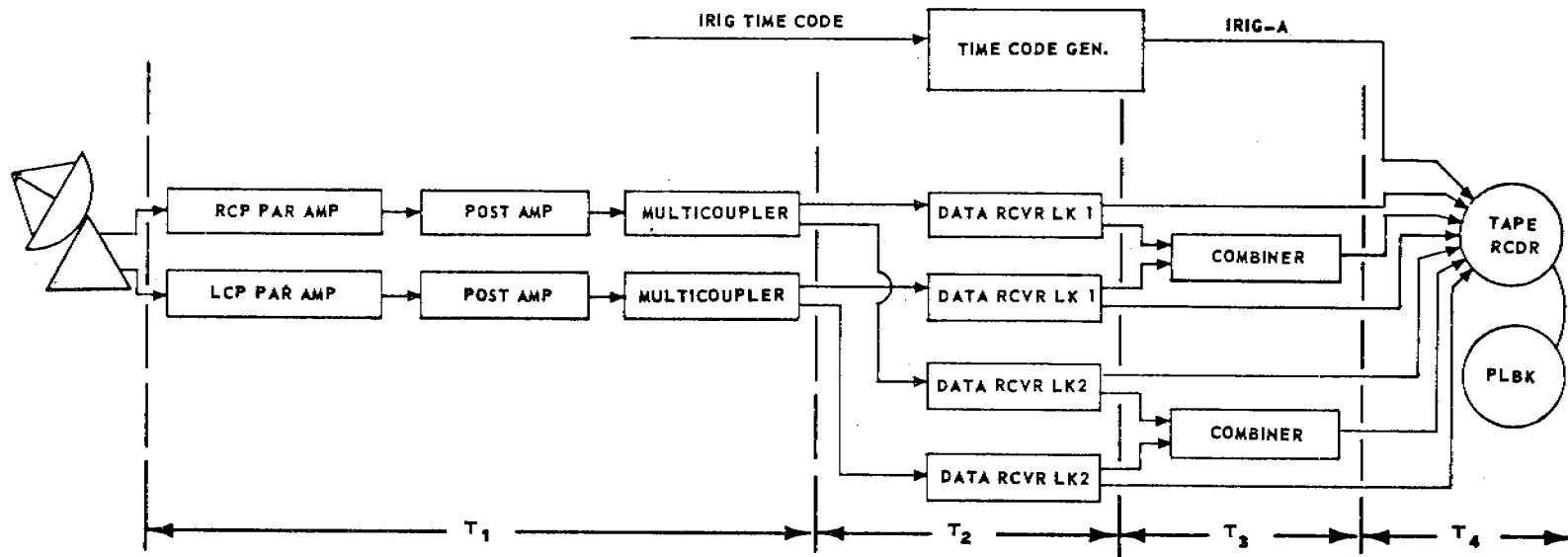

	PRE-DETECTION TIME DELAYS (η S)	POST-DETECTION TIME (η S)
T_1 = ANTENNA SYSTEM	508	508
T_2 = DATA RECEIVER	2035	1318
T_3 = COMBINER	237	78
T_4 = TAPE RECORDER	50	50
TOTAL RECEIVE SYSTEM TIME DELAY	2830 η S	1954 η S

Figure 5. Absolute RF System Receive/Record Time Delays

- NOTES:
1. THE REFERENCE TAPE WAS RECORDED ON A MODEL VR 3700A.
 2. FM RECORDING WAS DONE ON A 900 kHz VCO.
 3. TAPE SPEED = 120 ips.

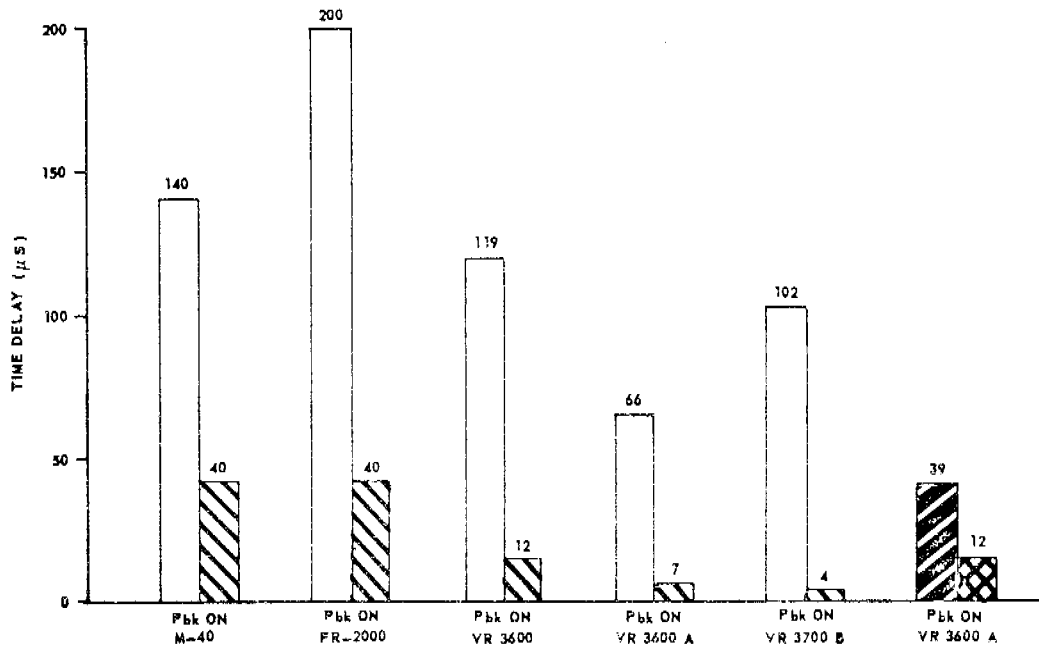
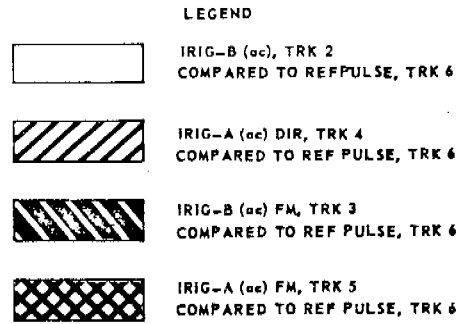

Figure 6. Comparison of Playback Time Delays of Different Brands of Recorder

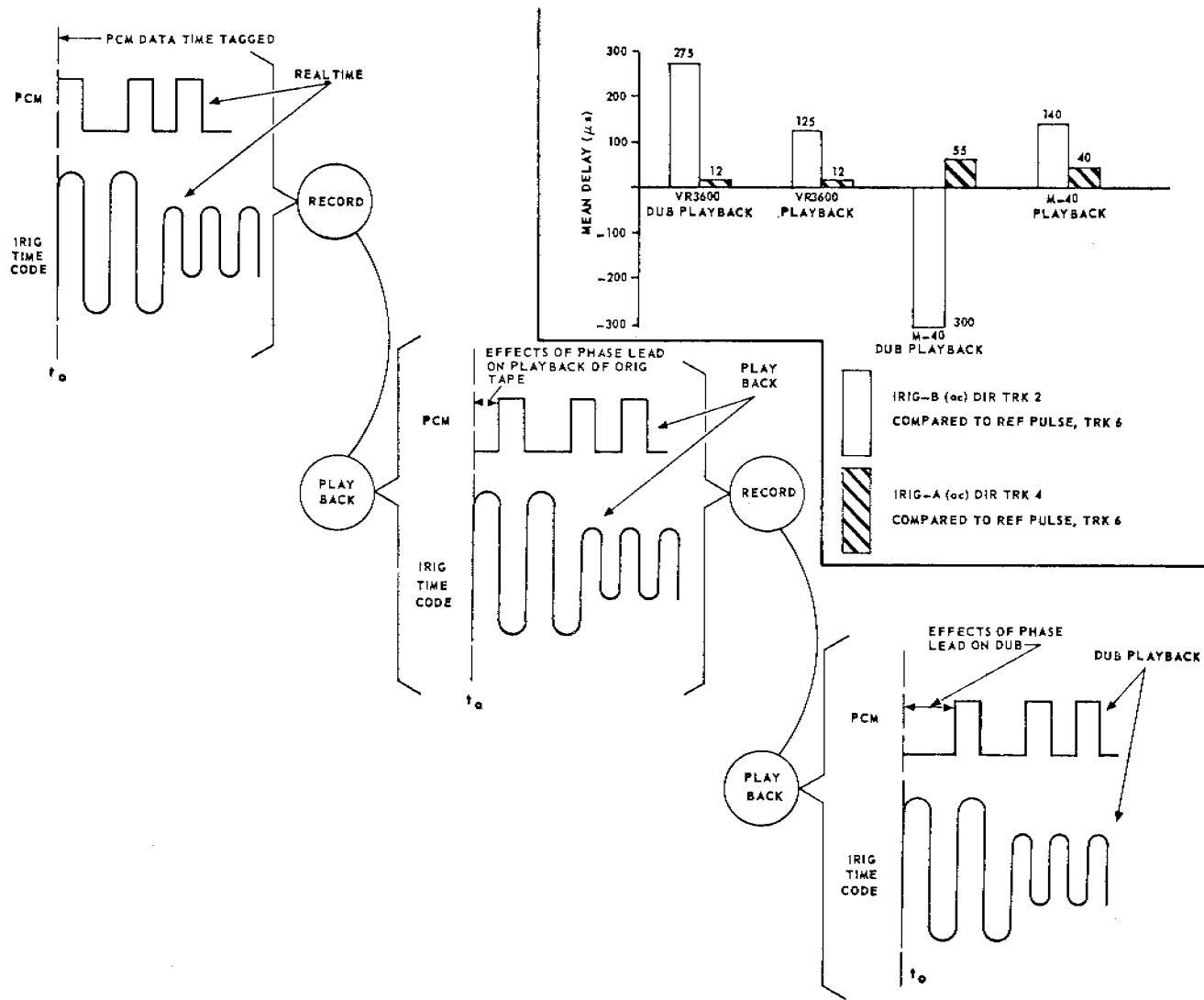

Figure 7. Time Delay Effects of Phase Lead on Dubbing

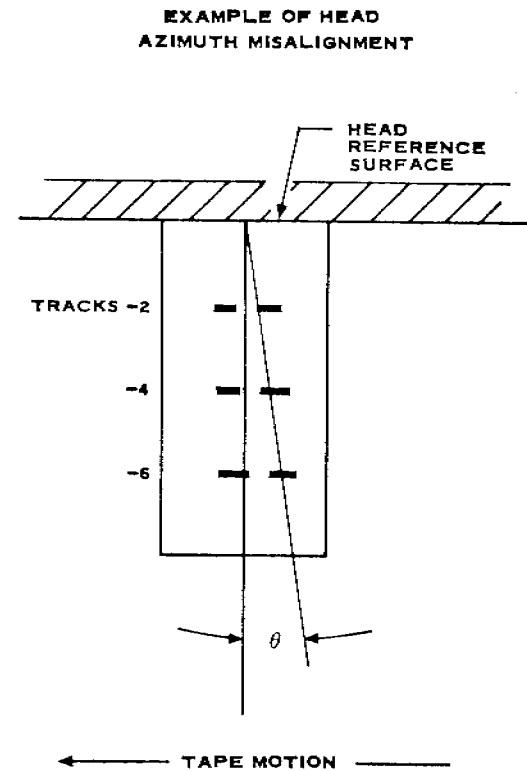
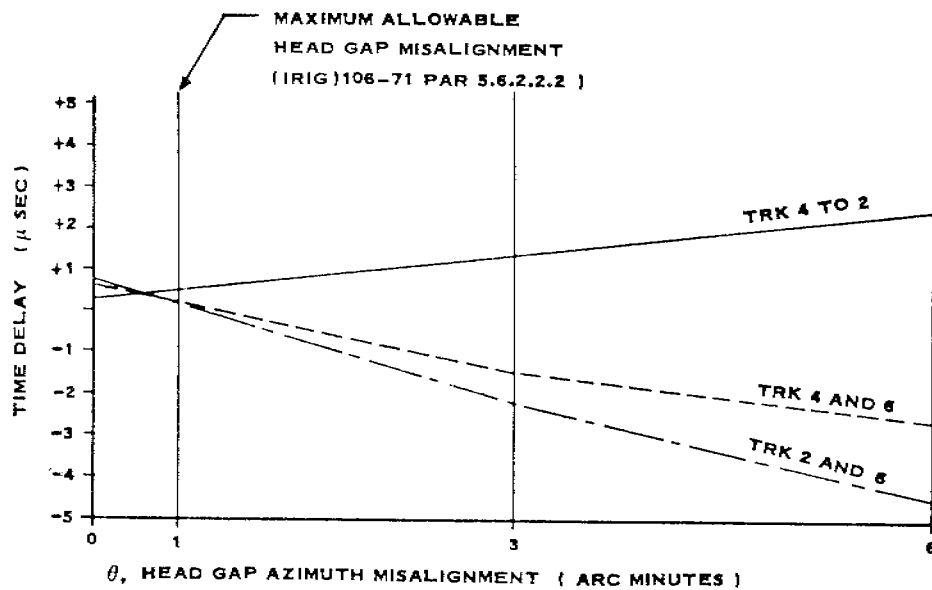
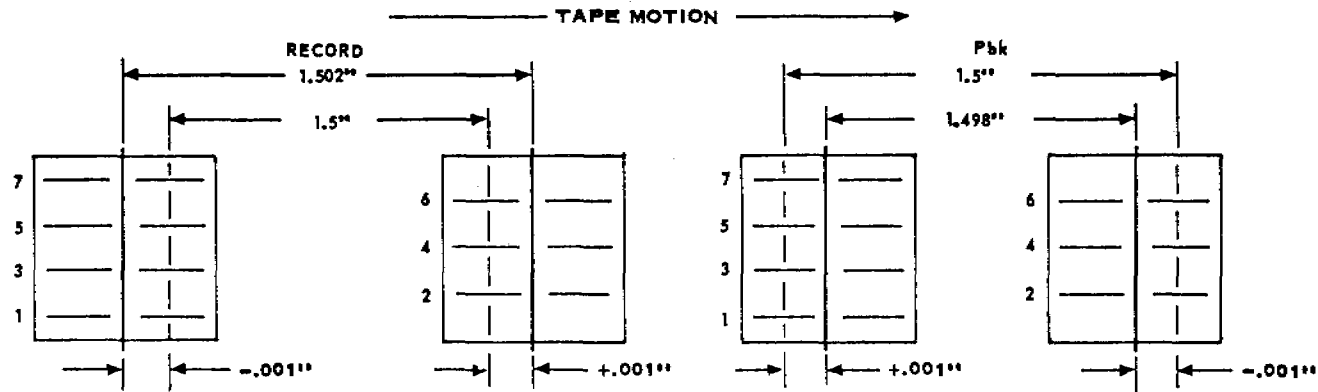
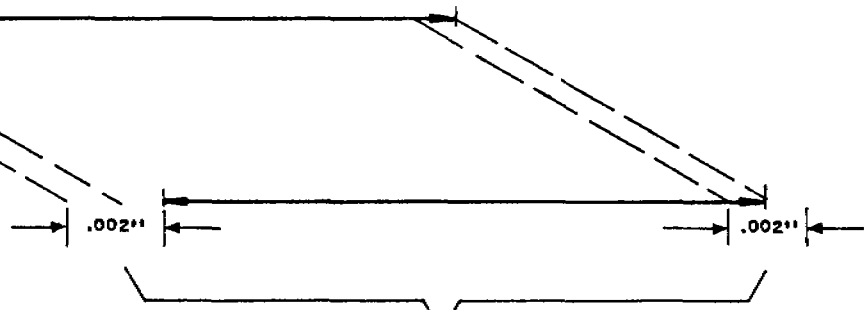

Figure 8. Time Delay Contributions Due to Recorder Head Gap Azimuth Misalignment



P.E. = PROBABLE ERROR
RHGCE = RECORD HEAD GAP CENTERLINE ERRORS
PHGCE = PLAYBACK HEAD GAP CENTERLINE ERRORS

$$\begin{aligned}
 P.E. &= \sqrt{(RHGCE)^2 + (PHGCE)^2} \\
 &= \sqrt{(.002")^2 + (.002")^2} \\
 &= 0.00283" \text{ OR } 23.6\mu S
 \end{aligned}$$



.004" ERROR IS WITHIN IRIG TOLERANCE
(I.E. 33.3 μ SECONDS ERROR)

PARAGRAPH 5.6.2.2.(b) OF IRIG DOCUMENT NO. 106 - 71
SPECIFIES THAT THE GAP CENTERLINE FOR WIDEBAND RECORDERS
WITH AZIMUTH ADJUSTMENT SHALL BE 38,10 ± 0,05 mm
(1.5 ± 0.002 INCHES) BETWEEN TWO STACKS OF A HEAD PAIR.

Figure 9. Effects of Recorder Head Stack Mechanical Placement

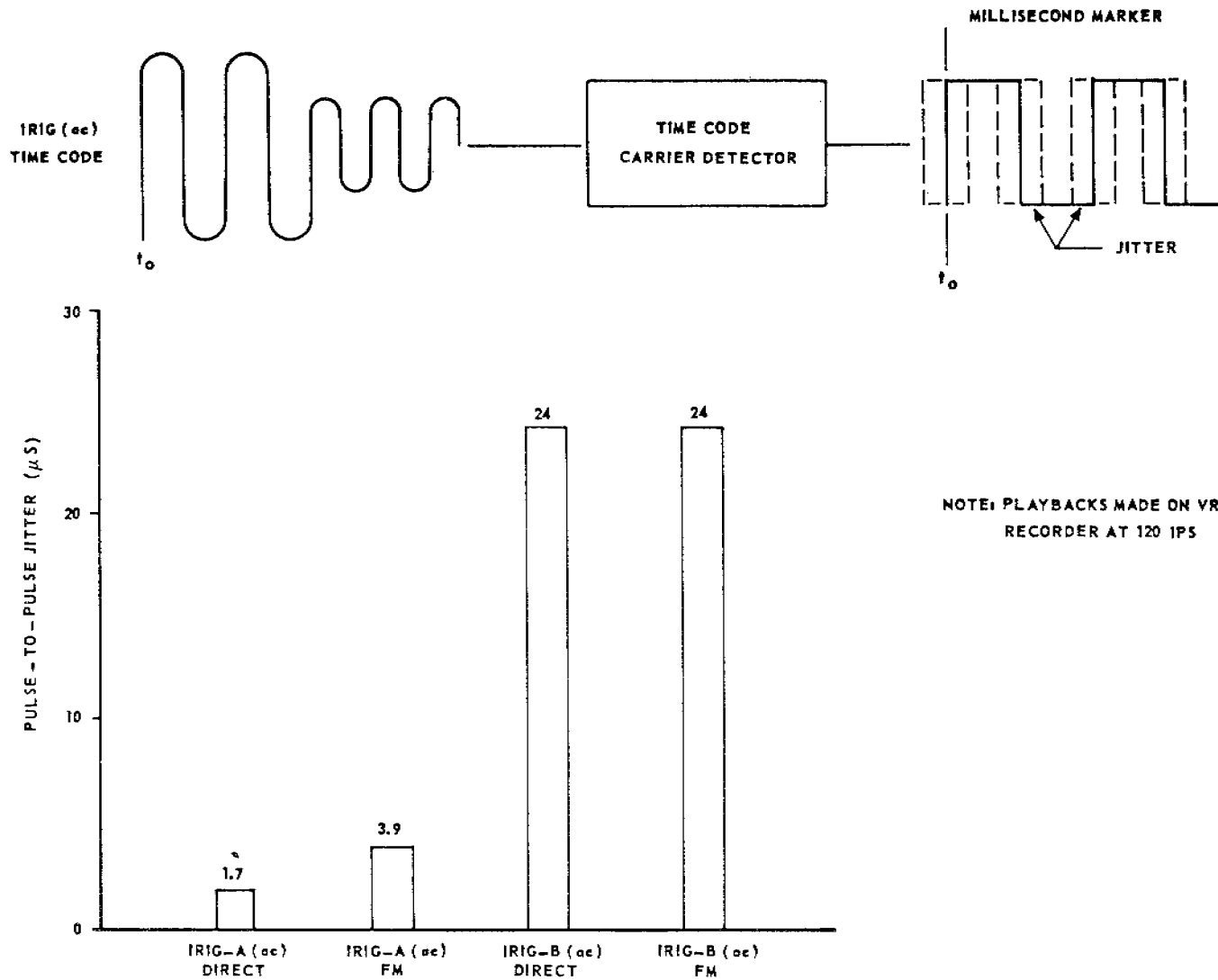

NOTE: PLAYBACKS MADE ON VR 3600A
RECORDER AT 120 IPS

Figure 10. Examples of Pulse-to-Pulse Jitter Caused by the Time Code Translator

- f. An unmodeled error occurs from time to time when the recorder IRIG timing is noisy. Operators may filter the data to obtain better lock. Such filtering introduces additional delay and amplifier inversion of the code may introduce an unexpected time delay of one half cycle (500μ sec for IRIG B). Such errors, of course, destroy the carefully controlled timing correlations.

Correction of Telemetry Errors

The errors outlined above may accumulate to several hundred microseconds on a given data run. Fortunately, the error is a reasonably constant value and can be easily determined as follows.

Referring to Figure 11, the delay to the signal conditioner 1 is known to be less than 2μ s and is ignored. The conditioner introduces a 1 bit data delay and its output is recorded on a redundant recorder track. Each 1 pps pulse from the time code generator switches the data off and inserts a pre-programmed word in the data. During processing, the special word can be easily identified and the last data bit prior to the word inserted is noted. This is the data bit which was received within 1 bit time of an even second mark (less the delay through the receiving system). The actual data produced from an uninterrupted (normal) input is then examined and the time provided by the computer for the reference bit determined. This time should be an even second. Any deviation is the accumulated timing error which existed at the even second. The mean and standard deviation of all 1 second measurements is obtained. This provides the timing bias caused by the accumulated error. The bias can be removed in subsequent processing operations.

Future Requirements

A range requirement may be received which requires that the data received on two separate links be correlated to within $\pm 10 \mu$ s. From the data provided above, it can be seen that even if the two data streams are recorded on the same head stack and high frequency IRIG codes are used, it will be difficult to control the computer inputs to within the required tolerance. Of greater significance, however, is the software resolution of ± 1 word time in assigning timing "tags". This resolution must be reduced to ± 1 bit time to meet program objectives.

Future Needs

Although cesium standards have proven reliable, failures require that a "flying clock" be sent to the remote site between normal calibration intervals. What is needed is a technique for synchronizing remote standards to within $\pm 1 \mu$ s

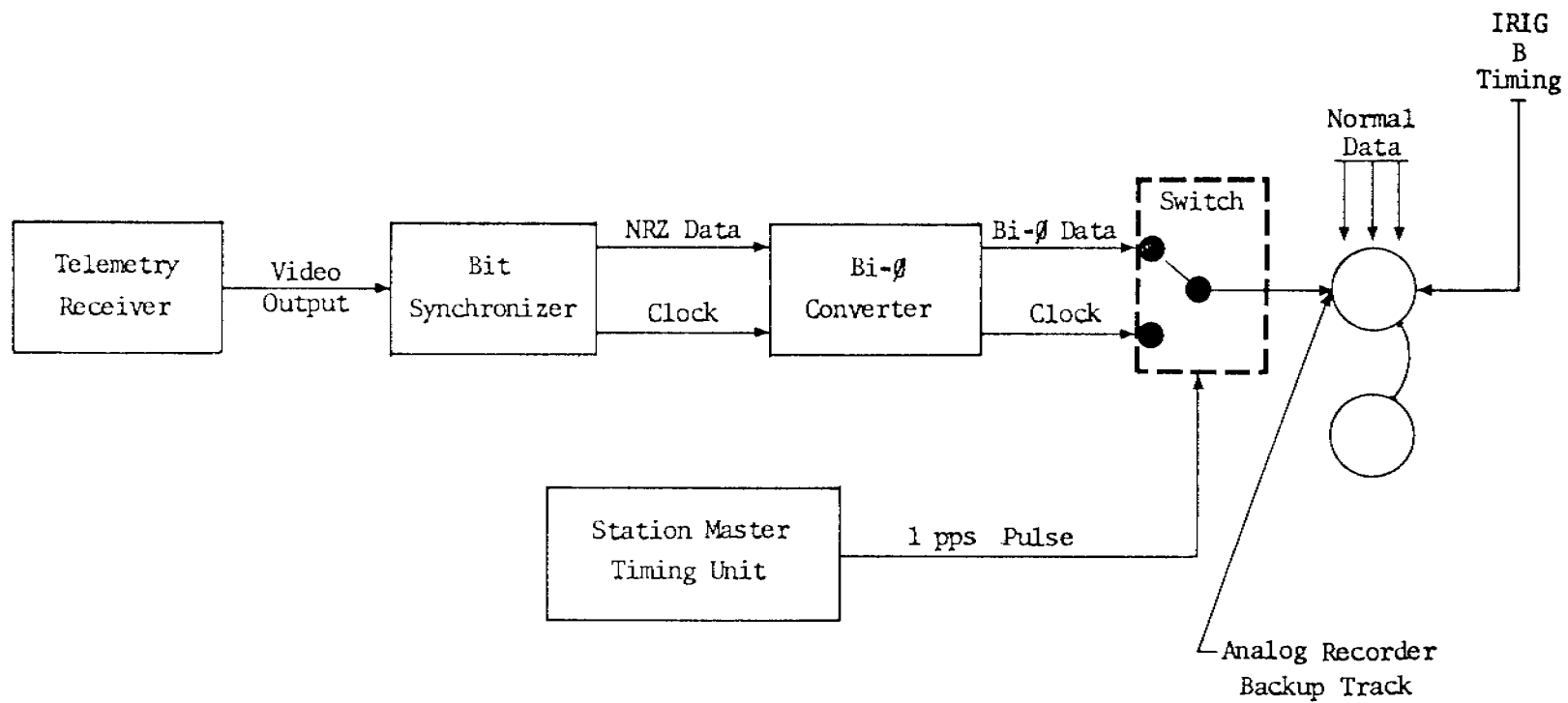

Figure 11. Real Time Telemetry Timing Marker System

without relying on a portable clock. The application of satellites has been considered and the accuracy appears to be satisfactory. However, its application depends on the availability of inexpensive receiving equipment which can compete, from a cost effectiveness standpoint, with the flying clock concept.

REFERENCES

1. Pickett, R. B., "Improving Telemetry Timing Accuracy", International Telemetering Conference Proceedings, 1971.
2. Matthews, F. L., "Timing Accuracies of Range Instrumentation Systems", International Telemetering Conference Proceedings, 1972.
3. Matthews, F. L. and Streich, R. G., "Timing Correlation in Telemetry Recording and Processing Systems", International Telemetering Conference Proceedings, 1973.
4. "Telemetry Standards", IRIG Document 106-73 (Revised May 1973).
5. "Test Methods for Telemetry Systems and Subsystems", IRIG Document 118-73 (Revised May 1973).
6. "IRIG Standard Time Formats", IRIG Document 104-70 (Revised August 1970).

QUESTION AND ANSWER PERIOD

MR. CHI:

Are there any questions?

DR. COSTAIN:

You never mentioned the quality or band width of the lines that you were using. I found that IRIG-B was even beyond the capability of commercial telephone lines, and the error rate was unacceptable, and we went to the FSK coding modems.

You are talking about using 100 kilohertz. You must have pretty good lines.

MR. MATTHEWS:

If and when we do go to the 100 kilohertz, of course it would be in the coax type line.

Normally, our IRIG-B is distributed, when it is on telephone lines, on a 3 KC circuit, and IRIG-A requires coax.

DR. WINKLER:

I am very impressed by the work which you have described. There are several comments and ideas which I would like to explore here with you.

Isn't it true that the absolute time difference which you have between your various channels on one and the same tape recorder, is less of a problem than the fluctuations which you have not only from gap misalignment, but even more so from changes in the tape tension, and changes in the tape type? If you use a different tape, I would expect you to have quite a different delay from channel to channel.

Don't forget that five microseconds at a speed of 120 inches per second amounts to just a few microns of difference in position at any one moment.

For that reason, it appears to me that it may be useful to make a test of trying to superimpose a low level sine wave, which is derived from your standard, on the very same channel on which you have your timing data coming in, which are, of course code modulated at any rate.

So, you could separate them electrically, but you would have the advantage of having passed all the signals, the timing signals, and your information over exactly the same channels on the tape.

Another possibility, of course, would be to use a wide band video recorder, and to put all your channels onto one carrier, and use actually a carrier frequency type of recording system.

But it is definitely pushing the possibilities to the very end.

MR. MATTHEWS:

Well, I failed to mention that we, in the alignment of our recorder heads, used the lissajous patterns to make our alignment, and have found it very effective in aligning up the head, as to the azimuth alignment.

MR. KLEINKOPF:

Jack Kleinkopf here, from NASA Flight Research Center, at Edwards Air Force Base.

One thing that I didn't get clear -- maybe you covered it -- was the discrepancy between your sample data system, the PCM system, and the sample rate on board, and the ground timing.

How do you go about resolving that?

MR. MATTHEWS:

I should say airborne timing is not available on the missiles that are flown out of Vandenberg, and therefore all of the timing is generated from the ground system.

Does that answer your question?

MR. KLEINKOPF:

Well, do you have an oscillator in your airborne sample data system, and do you have a frame of PCM data coming in, so that the post reduction analysis can go back and determine where the beginning of the frame of the PCM data is with respect to your ground base time.

MR. MATTHEWS:

Okay. Normally, there are specific points in the flight that are known very accurately, and we can align our data up with time at these points, such as when they go through staging. These represent specific time intervals which we know. At those points we know that at a certain time that, because of separation or attenuation, we get dropouts. We also know that these particular points in our data stream are exact and that we can line the timing up with that.

MR. KLEINKOPF:

I see. You are saying this is all based on a launch time, or something like that, initialization point.

MR. MATTHEWS:

We record the liftoff time. But one of the points that I was pointing out, I believe on the last slide there, was that in order to measure the absolute time, we need to know very accurately what the time delay difference is between UTC and this one pps pulse where we insert the pre-programmed word into the data stream with a special recorded track.

That data is pulled off, put into the computer, and stored. It is also looking and averaging the time of the millisecond marker — that is, the IRIG time code goes into the time code translator. It then inputs the millisecond markers into the computer, and it knows at a certain point this one pps pulse takes place where that millisecond marker should be. We then correct for that millisecond marker.

MR. CHI:

Thank you again.