

**TCI-NENA
(911/PSAP)**

TIME CODE INTERFACE



TABLE OF CONTENTS

DISCLAIMER.....	2
INTRODUCTION.....	3
Features At A Glance.....	3
Documentation.....	3
FEATURES.....	3
Time Code Conversion/Output.....	3
Time Zone/Daylight Savings Time Adjustment.....	3
RS-232 Serial Interface.....	3
INITIAL OPERATION.....	4
NORMAL OPERATION.....	4
SETUP AND CONFIGURATION VIA INTERNAL SWITCHES.....	4
Setup and I/O Options.....	4
Access to PC Board.....	4
FIGURE 1.....	5
TC Source Selection.....	5
TIME CODE GENERATOR CONFIGURATION.....	5
Step 1: Time Code Generator Selection.....	5
Step 2: Signal Output Selection.....	6
Step 3: Signature Control.....	6
Long-Term Stability.....	6
TIME ZONE/DAYLIGHT SAVINGS TIME ADJUSTMENTS.....	6
Time Zone Offset Selection.....	6
Daylight Savings Time Selection.....	7
Configuration Error.....	7
SERIAL PORT CONFIGURATION.....	7
Baud Rate Selection.....	7
Broadcast/Bi-Directional Output Selection.....	7
Output Format Selection.....	7
SW3-1 SW3-2 Format selected.....	7
PHYSICAL CONNECTIONS/CONFIGURATION.....	7
Simplified I/O Connections.....	7
Figure 2.....	8
PROBLEMS - TROUBLE SHOOTING.....	8
SPECIFICATIONS.....	9
FUNCTIONAL.....	9
Serial Communications.....	9
HARDWARE.....	9
Operating Environment.....	9
TTL Level Outputs.....	10
Dry Contact Closure.....	10
Battery Operation.....	10
LIMITED WARRANTY.....	10
Exclusions.....	10
Warranty Limitations.....	10
Exclusive Remedies.....	11
HARDWARE SERVICE.....	11

DISCLAIMER

The information contained in this document is subject to change without notice. Masterclock, Inc. makes no warranty of any kind with regard to this material, including, but not limited to, the implied warranties of merchantability and fitness for a particular purpose.

Masterclock, Inc. shall not be liable for errors contained herein or for incidental or consequential damages in connection with the furnishing, performance, or use of this material.

See limited warranty information starting on page 10.

INTRODUCTION

Masterclock, Inc. suggests a basic configuration as a solution for the PSAP master clock system:

- GPS200 master clock (Qty = 1)
- TCI-NENA time code interface (Qty = 1 or 2)
- TCD200 time display (Qty = 1)

Features At A Glance

- operate from IRIG-B or SMPTE time code inputs
- 12/24 hour configurable time display module
- IRIG-B modulated or pulse-width encoded time code output
- IRIG-E modulated or pulse-width encoded time code output
- all time code outputs support signature control
- all time code outputs encode NENA extensions
- supports NENA-defined format 0/format 1 ASCII outputs at 9600, 4800, 2400, and 1200 baud
- perform time zone adjustments in display, serial, and time code outputs
- perform daylight savings time adjustment in display, serial, and time code outputs
- provides dry contact closure alarm for time code or power loss

Documentation

Operation manuals for the GPS200 master clock and TCD200 time display have been included separately in your package. Masterclock, Inc. recommends leaving the configuration of the GPS200 at the factory-configured defaults. You may want to re-configure the TCD200 to achieve time zone and daylight time adjustments. Consult the TCD200 manual for additional information. The remainder of this documentation will pertain to the TCI-NENA interface unit which provides the NENA-04-002 outputs.

Masterclock, Inc. recommends that users of this product avail themselves of the NENA-04-002 master clock specification which provides addition details regarding the NENA uses and requirements for the outputs of this package. The specification can be downloaded from the NENA web page at <http://www.nena.org>

FEATURES

Time Code Conversion/Output

The TCI-NENA can provide a conversion from any SMPTE or IRIG-B time code signal, to the NENA-specified outputs - IRIG-B, IRIG-E, and ASCII serial messages. Your NENA master clock package was configured at the factory to accept SMPTE time code input from the GPS200 master clock. Time code is output on the DB-9 on the rear of the unit.

Time Zone/Daylight Savings Time Adjustment

The TCD200 time display and the TCI-NENA interface box can be independently configured for time zone offsets. Offsets from -11.5 to +12 hours (in 30 minute increments) can be selected. Use of the daylight savings time adjustment feature requires SMPTE time code with date encoding. This is provided by the default configuration of the GPS200 master clock. *Consult the TCD200 manual for more information on configuring the display unit.*

RS-232 Serial Interface

NENA-specified ASCII serial output is available on the DB-9 connector on the rear of the unit. Output can be configured for 9600, 4800, 2400, and 1200 baud. Bi-directional (output on request) or broadcast output is a configurable option.

When configured for bi-directional (output on request) mode a carriage return (ASCII 13) is sent by the client application to request transmission of the time string. Transmission will begin immediately following the receipt of the character.

When configured for broadcast mode TCI-NENA will output the time string once per second at the beginning of the second. The leading edge of the start bit of the first character of the message is the “on-time” mark for the time encoded in the string.

Dry Contact Closure

A dry contact closure alarm is available on the DB-9 connector on the rear of the unit. The contact is closed during periods of power loss or time synchronization failure.

INITIAL OPERATION

Setup for initial operation consists of:

- time zone/daylight time and other miscellaneous configuration on TCI-NENA interface
- time zone/daylight time configuration of TCD200 display

NORMAL OPERATION

When power is first applied (without TC present) the front panel LED will come on and stay on.

After power up (when TC is present) and after initialization, the LED will flash once each second in synchronization with the on-time mark of the generated TC.

Should TC be lost or become invalid the LED will stay on but will not blink

SETUP AND CONFIGURATION VIA INTERNAL SWITCHES

SETUP AND I/O OPTIONS

Various setup parameters can be configured by setting switches inside the case.

Access to PC Board

In order to gain access to the setup switches it is necessary to remove the case from the TCI-NENA as follows:

First disconnect the power and other cables from the unit. Even though the highest voltage inside the TCI-NENA is potentially up to 28 VDC (which is generally not dangerous to touch), accidentally shorting a trace or wire inside the unit with power on could destroy or damage any one of the extremely sensitive electronic modules. **Accidentally shorting a wire or trace or subjecting the unit to a static discharge, even for a very small fraction of a second, can destroy these modules. Such damage is not covered by the warranty.**

Remove the two Phillips screws on the rear panel (this is the end with the power socket, BNC, and DB-9 connectors). Holding the case of the unit in one hand, slide the rear panel assembly outward from the rear. The entire rear panel assembly and PC board will slide out.

As was mentioned above, the PC board is sensitive to any electrical signal including static discharge. Do not touch the PC board with any external wiring and, whenever possible, handle the unit by the rear panel or on the edge of the PC board as you would a Compact Disc. When not changing the switches, always keep the PC board installed in the case.

When reassembling the unit take care that the PC board is properly fitted into the slots in the base of the chassis. When properly inserted, the PC board and rear panel assembly will slide easily into the case, no force is necessary. The warranty does not cover damage caused to the unit while removing or reassembling the PC board.

Figure 1 shows the location of the various switches and jumpers on the PC board.

FIGURE 1

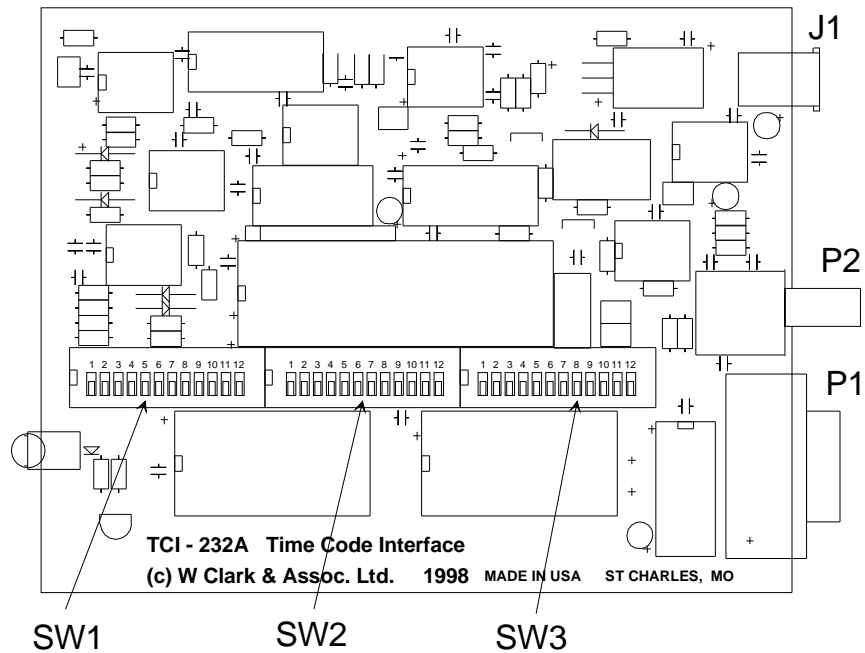

TC source select can be configured via the SW1 switch bank.

TC Source Selection

SW1-1	SW1-2	SW1-3	SW1-4	TC source selected
OFF	OFF	OFF	OFF	Auto-detect
ON	OFF	OFF	OFF	SMPTE (30, 25, or 24 fps) (<i>default</i>)
OFF	ON	OFF	OFF	IRIG-B(1) 1kHz modulated
ON	ON	OFF	OFF	IRIG-B (unmodulated)

TIME CODE GENERATOR CONFIGURATION

The TCI-NENA provides all of the following time code outputs:

- IRIG-B modulated
- IRIG-B pulse-width encoded
- IRIG-E modulated
- IRIG-E pulse-width encoded

Step 1: Time Code Generator Selection

SW1-5	SW1-6	SW1-7	SW1-8	TC generator selected
OFF	OFF	OFF	OFF	IRIG-B (both formats) (<i>default</i>)
ON	OFF	OFF	OFF	IRIG-E (both formats)

Step 2: Signal Output Selection

SW3-9	SW3-10	SW3-11	SW3-12	TC signal selected*
OFF	OFF	OFF	OFF	no signal output
ON	OFF	OFF	OFF	IRIG-B/E pulse-width encoded
OFF	ON	OFF	OFF	-- reserved --
OFF	OFF	ON	OFF	-- reserved --
OFF	OFF	OFF	ON	IRIG-B/E modulated

* Note: under no circumstances should more than one of SW3-9 – SW3-12 be switches ON at a given time.

Step 3: Signature Control

Enabling signature control inhibits time code output (per NENA-04-002 specification) when the master clock becomes unsynchronized with GPS satellites.

SW2-7 – ON Enable signature control
 SW2-7 – OFF Disable signature control (*default*)

Long-Term Stability

The long-term accuracy and stability of the TCI-NENA generated TC is the same as that of the TC source. When using GPS-200 as time code source long-term accuracy (when synchronized) is traceable to within 500us (microseconds) of UTC. When unsynchronized worst-case drift of the time reference is 86ms/day.

TIME ZONE/DAYLIGHT SAVINGS TIME ADJUSTMENTS

The TCI-NENA can apply time zone offsets to the generated time code data. Offsets can be configured for –11.5 to +12 hours (in 30 minute increments). Any offsets specified will be relative to the time code source time zone encoding.

If date information is available in time code source and encoded in a format the TCI-NENA recognizes the daylight savings time adjustment option is available. *This is always the case when the GPS-200 is the master clock source of time.* When enabled this feature applies daylight savings time adjustments to generated time code during US/Canada-defined daylight time. The adjustment is calculated relative to the time code source reference after any TCI-NENA-specified hour offset has been applied.

Time Zone Offset Selection

SW2-1	SW2-2	SW2-3	SW2-4	Hour offset
OFF	OFF	OFF	OFF	0 hour-no offset (<i>default</i>)
ON	OFF	OFF	OFF	1 hour
OFF	ON	OFF	OFF	2 hours
ON	ON	OFF	OFF	3 hours
OFF	OFF	ON	OFF	4 hours
ON	OFF	ON	OFF	5 hours
OFF	ON	ON	OFF	6 hours
ON	ON	ON	OFF	7 hours
OFF	OFF	OFF	ON	8 hours
ON	OFF	OFF	ON	9 hours
OFF	ON	OFF	ON	10 hours
ON	ON	OFF	ON	11 hours
OFF	OFF	ON	ON	12 hours

SW2-5 – ON Additional ½ hour offset
 SW2-5 – OFF No ½ hour offset (*default*)

SW1-12 – ON Specified offset is negative
 SW1-12 – OFF Specified offset is positive (*default*)

Daylight Savings Time Selection

SW2-6 – ON Daylight time adjustment enabled*
SW2-6 – OFF No daylight time adjustment (*default*)

Configuration Error

* Note: if no date is detected in time code source and this option is enabled the TCI-NENA will revert to a non-operational state where the front-panel LED will blink rapidly. To correct the situation, disable daylight time adjustment or apply a time code signal that provides date encoding then restart the unit.

SERIAL PORT CONFIGURATION

The serial port of the TCI-NENA can be configured at baud rates between 1200 – 9600 baud. The ASCII serial output can also be configured as broadcast or bi-directional (output on request).

Baud Rate Selection

SW1-9	SW1-10	SW1-11	Baud Rate selected
OFF	OFF	OFF	9600 baud (<i>default</i>)
ON	OFF	OFF	4800 baud
OFF	ON	OFF	2400 baud
ON	ON	OFF	1200 baud

Broadcast/Bi-Directional Output Selection

SW2-8 – ON Bi-direction (output on request) serial transmission enabled
SW2-8 – OFF Broadcast (once/second) serial transmission (*default*)

Output Format Selection

SW3-1	SW3-2	Format selected
OFF	OFF	Format 0 (<i>default</i>)
ON	OFF	Format 1

PHYSICAL CONNECTIONS/CONFIGURATION

All I/O functions are available on P1 at all times in addition to the TC. If only the time code output is used, a DB9 to BNC adapter is available from Masterclock, Inc. (part no. BNC-9). Contact the factory for ordering information.. To simultaneously use some combination of functions a custom I/O cable will be necessary. Such cables can be fabricated locally by an electronic technician or on a custom basis by MASTERCLOCK.

SIMPLIFIED I/O CONNECTIONS

FIGURE 2

SIMPLIFIED I/O P1 - DB-9

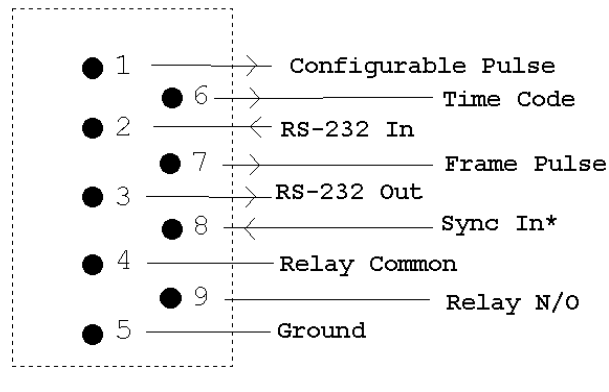

Input Connections

Connect the TC to the BNC connector on the rear of the TCI-NENA. The BNC input is isolated from chassis ground, is balanced, and has an input impedance of > 100K ohm.

Time Code Interconnect Cable

Time Code is an audio signal similar to that of a modem. It can be routed over shielded audio wire, unshielded wire such as telephone wire or, if desired, over inexpensive RG-58/59 coaxial cable.

Time Code Signal Level

The input level of TC to the TCI-NENA should be in the range of -20 to +20 DB (600 ohms). The unit will automatically calibrate to any input voltage level within this range. Levels outside this range may not be decoded by the TCI-NENA.

Output Connections

All outputs of the TCI-NENA are available on the DB-9 connector on the rear of the unit.

PROBLEMS - TROUBLE SHOOTING

All TCI-NENA units are checked for proper operation before shipment and unless physical damage is found, the unit is probably functional.

If you have problems getting the unit to work:

- verify that the GPS-200 master clock (if used) is locked and generating reference time (*consult GPS-200 manual for more information*)
- double check all input and output connections
- make sure that power is applied and the front panel LED is showing the startup sequence when first activated
- verify that a valid TC is connected
- verify that the TC input level is in range

If the unit does not work even after the above precautions have been noted contact the factory.

SPECIFICATIONS

FUNCTIONAL

Time Code Input

Format:..... Selectable
Level:..... -20 - +20dBm (600 ohm)
Impedance:..... > 100K ohm
Connector:..... BNC male

Time Code Output

Connector:..... DB-9 male

IRIG-B/E modulated:..... Approx. - 5Vpp
Impedance:..... < 50 ohm

IRIG-B/E pulse-width encoded: . Approx. - 5Vpp
Impedance:..... < 50 ohm

Time Code Output Accuracy

Latency from incoming TC..... < +/-500 μ sec

Serial Communications

ASCII serial output..... 8 data bits, 1 stop bit, no parity

FORMAT 0

<CR><LF>I<^><^>DDD<^>HH:MM:SS<^>DTZ=XX<CR><LF>

KEY:

<CR> Carriage return
<LF> Line feed
<I> Sync Status: ^ = sync; ? = sync lost; * = Manual Set
<^> Space
<DDD> Day of Year (001-366)
<HH:MM:SS> Hours:Minutes:Seconds
<D> Daylight saving indicator (S,I,D,O)
<XX> Time Zone Setting (00-23)

FORMAT 1

<CR><LF>I<^>WWW<^>DDMMYY<^>HH:MM:SS<CR><LF>

KEY:

<CR> Carriage return
<LF> Line feed
<I> Sync Status: ^ = sync; ? = sync lost; * = Manual Set
<^> Space
<WWW> Day of week: SUN|MON|TUE|WED|THU|FRI|SAT
<DD> Numerical day of month, 1-31
<MMM> JAN|FEB|MAY|JUN|JUL|AUG|SEP|OCT|NOV|DEC
<YY> Year, 00-99
<HH:MM:SS> Hours:Minutes:Seconds

HARDWARE

Operating Environment

The TCI-NENA is not water or moisture proof. Treat it as you would any other delicate electronic device and do not expose it to water, moisture, excessive heat or physical abuse.

TTL Level Outputs

The configurable and frame rate pulse outputs of the TCI-NENA are high impedance TTL level signals and are not designed to drive relays and other low impedance devices directly. Connecting such devices, including shorting the output pin, and causing more than approximately 2 ma of current to flow, could damage the unit. Such damage is not covered by warranty

Dry Contact Closure

The absolute maximum contact rating is .5 Amp at 24 VDC. Nominal current should not exceed 200 ma. Connecting high current loads and exceeding the recommended rating could damage the relay and traces on the PC board. Such damage is not covered by warranty.

Power Supply Requirements

- Input voltage nominal 12 VDC (9-18 VDC)
- Input power connector 2 mm male plug
- Power consumption..... approximately 200 ma (2.4 W)

Battery Operation

If desired the unit can be operated from a 12 VDC power source (9-15 VDC range). Observe voltage polarity - printed on the rear panel.

Physical

- Size: 1.5 x 4.1 x 5.5 in. (3.8 x 10.4 x 14 cm)
- Weight..... 17 oz. (480 gr.)

Operating Temperature

Temperature..... 0 to +60 °

LIMITED WARRANTY

This W Clark & Associates, Ltd. (hereinafter MASTERCLOCK) product warranty extends to the original purchaser.

MASTERCLOCK warrants the TCI-NENA against defects in materials and workmanship for a period of five years from date of sale. If MASTERCLOCK receives notice of such defects during the warranty period, MASTERCLOCK will, at its option, either repair or replace products which prove to be defective.

Should MASTERCLOCK be unable to repair or replace the product within a reasonable amount of time, the customer's alternate remedy shall be a refund of the purchase price upon return of the product to MASTERCLOCK. This warranty gives the customer specific legal rights. Other rights, which vary from state to state or province to province, may be available.

EXCLUSIONS

The above warranty shall not apply to defects resulting from improper or inadequate maintenance by the customer, customer-supplied software or interfacing, unauthorized modification or misuse, operation outside of the environmental specifications for the product or improper site preparation and maintenance (if applicable).

WARRANTY LIMITATIONS

MASTERCLOCK MAKES NO OTHER WARRANTY, EITHER EXPRESSED OR IMPLIED, WITH RESPECT TO THIS PRODUCT. MASTERCLOCK SPECIFICALLY DISCLAIMS THE IMPLIED WARRANTIES OF MERCHANTABILITY OR FITNESS FOR A PARTICULAR PURPOSE.

In any state or province which does not allow the foregoing disclaimer, any implied warranty of merchantability or fitness for a particular purpose imposed by law in those states or provinces is limited to the one-year duration of the written warranty.

EXCLUSIVE REMEDIES

THE REMEDIES PROVIDED HEREIN ARE THE CUSTOMER'S SOLE AND EXCLUSIVE REMEDIES. IN NO EVENT SHALL MASTERCLOCK BE LIABLE FOR ANY DIRECT, INDIRECT, SPECIAL, INCIDENTAL, OR CONSEQUENTIAL DAMAGES, WHETHER BASED ON CONTRACT, TORT, OR ANY OTHER LEGAL THEORY.

In any state or province which does not allow the foregoing exclusion or limitation of incidental or consequential damages, the customer may have other remedies.

HARDWARE SERVICE

You may return your TCI-NENA to MASTERCLOCK for repair either under warrant or on a time & material basis. Please contact the factory for return authorization before returning the unit. When you return your TCI-NENA for service, you must prepay all shipping charges, duty, and taxes. For international returns please contact the factory.